

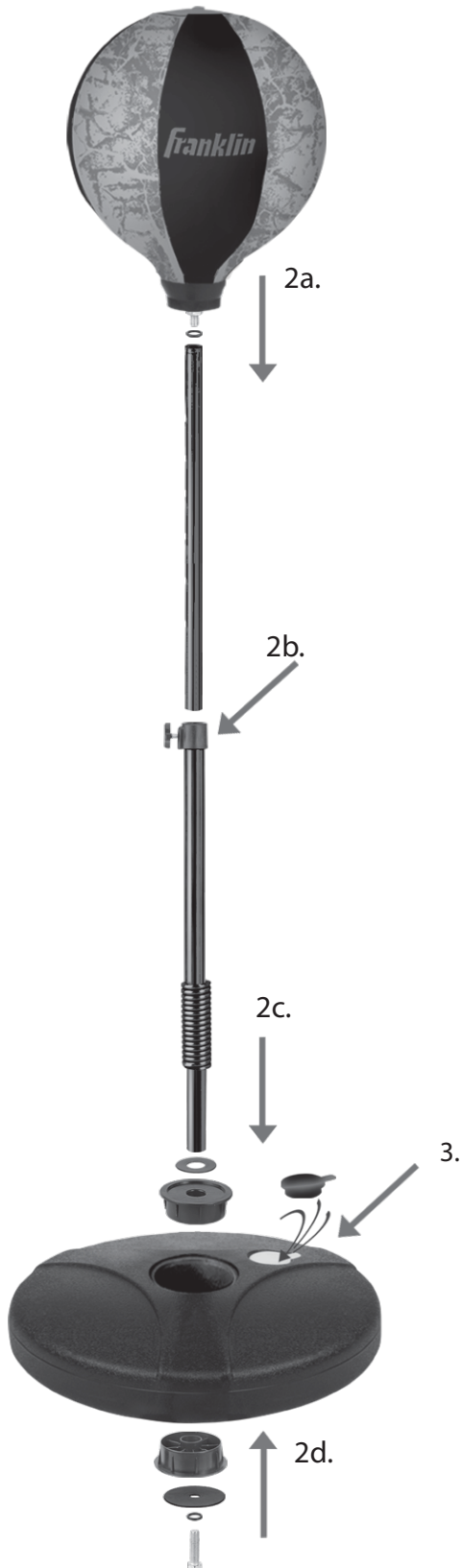

Youth MMA Floor Standing Speed Bag

Item #14188



1. Inflate the punching bag using the inflation pump and needle.

2. Assemble the speed bag by following the diagram shown.

a. Twist the punching bag into the top of the pole.

b. Screw the bolt to tighten at the desired height.

c. Slide the bottom pole through the ring and base insert and into the base.

d. The screw slides through the rings and base insert and twists into the bottom pole.

3. Fill the base with water or sand for added stability.



WARNING:
CHOKING HAZARD--Small parts.
Not for children under 3 yrs.

Franklin Sports Inc.
Stoughton, MA 02072
Made in China

For replacement parts call 1-781-341-5178
or 1-800-225-8649 OR visit www.franklinsports.com