

Choose from 8 Different Game Options (cont):

8. One to One

- Press "PLAY" to enter game 8
- Press "UP/Down" to select playing time, 30/45/60 seconds
- Press "PLAY" to begin the game
- Shot made in "HOME" frame, 2 points scored for "HOME", all shots count 3 points in last 10 seconds
- Shot made in "Visitor" frame, 2 points scored for "Visitor", all shots count 3 points in last 10 seconds
- Player with more points scored wins when time is out
- Press "PLAY" to restart this game

CHANGES OR MODIFICATIONS NOT EXPRESSLY APPROVED BY THE PARTY RESPONSIBLE FOR COMPLIANCE COULD VOID THE USER'S AUTHORITY TO OPERATE THE EQUIPMENT.

NOTE: THE EQUIPMENT HAS BEEN TESTED AND FOUND TO COMPLY WITH THE LIMITS FOR A CLASS B DIGITAL DEVICE; PURSUANT TO PART 15 OF THE FCC RULES. THESE LIMITS ARE DESIGNED TO PROVIDE REASONABLE PROTECTION AGAINST HARMFUL INTERFERENCE IN A RESIDENTIAL INSTALLATION. THIS EQUIPMENT GENERATES, USES AND CAN RADIATE RADIO FREQUENCY ENERGY AND, IF NOT INSTALLED AND USED IN ACCORDANCE WITH THE INSTRUCTIONS, MAY CAUSE HARMFUL INTERFERENCE TO RADIO COMMUNICATIONS. HOWEVER, THERE IS NO GUARANTEE THAT INTERFERENCE WILL NOT OCCUR IN A PARTICULAR INSTALLATION. IF THIS EQUIPMENT DOES CAUSE HARMFUL INTERFERENCE TO RADIO OR TELEVISION RECEPTION, WHICH CAN BE DETERMINED BY TURNING THE EQUIPMENT OFF AND ON, THE USER IS ENCOURAGED TO TRY TO CORRECT THE INTERFERENCE BY ONE OR MORE OF THE FOLLOWING MEASURES:

- REORIENT OR RELOCATE THE RECEIVING ANTENNA.
- INCREASE THE SEPARATION BETWEEN THE EQUIPMENT AND RECEIVER.
- CONNECT THE EQUIPMENT INTO AN OUTLET ON A CIRCUIT DIFFERENT FROM THAT TO WHICH THE RECEIVER IS CONNECTED.
- CONSULT THE DEALER OR AN EXPERIENCE RADIO/TV TECHNICIAN FOR HELP.

This device complies with part 15 of the FCC Rules. Operation is subject to the following two conditions: (1) This device may not cause harmful interference, and (2) this device must accept any interference received, including interference that may cause undesired operation.

Made in China
Franklin Sports Inc.
Stoughton, MA. 02072
www.franklinsports.com

Franklin[®]

Franklin[®]

7+

19798 Rebound Pro Frame Game Basketball

Congratulations on owning a new Franklin Sports Dual Court Basketball set! We strive to ensure that our products are of the highest quality and free of manufacturing defects or missing parts.

For replacement parts call
1-781-341-5178 or 1-800-225-8649
or visit www.franklinsports.com

Please have your model number when inquiring about parts. Your model #: 19798S11



CAUTION:
Adult assembly required



WARNING:
CHOKING HAZARD--Small parts.
Not for children under 3 yrs.

Parts List:

| | | | | | | | |
|----|-----------------------------------|----|--------------------------------------|----|--------------------------------------|----|----------------------------------|
| 1 | NET HANGER TUBE | 2 | VERTICAL BOARD SUPPORT MOUNTING TUBE | 3 | LEFT VERTICAL SUPPORT TUBE | 4 | RIGHT VERTICAL SUPPORT TUBE |
| 5 | FRAME SUPPORT TUBE | 6 | ANGLE TOP FRAME SUPPORT TUBE (LEFT) | 7 | ANGLE TOP FRAME SUPPORT TUBE (RIGHT) | 8 | LEFT HORIZONTAL FRAME BRACE TUBE |
| 9 | RIGHT HORIZONTAL FRAME BRACE TUBE | 10 | HORIZONTAL CROSS BRACE TUBE | 11 | MIDDLE RAMP TUBE (LEFT) | 12 | MIDDLE RAMP TUBE (RIGHT) |
| 13 | FRONT RAMP TUBE | 14 | FRONT HORIZONTAL RAMP SUPPORT TUBE | 15 | STEEL HOOK | 16 | M6 x 65MM BOLT |
| 17 | M6 WING NUT | 18 | M6 x 58MM BOLT | 19 | M6 WASHER | 20 | SPRING WASHER |
| 21 | M6 x 48 MM BOLT | 22 | INFLATING PUMP AND NEEDLE | 23 | LOCK PIN | 24 | M6 x 40MM BOLT |
| 25 | PLASTIC WASHER | 26 | ELECTRONIC SCORER FACE PLATE | 27 | BASKETBALL NET | 28 | M6 x 30 MM BOLT |
| 29 | BALL RETURN | 30 | 1/4" x 37 MM WING NUT BOLT | 31 | RIM SUPPORT PLATE | 32 | ELECTRONIC SCORER |
| 33 | BACKBOARD (NO ELECTRONICS) | 34 | BASKETBALL RIM | 35 | 3.5 X 10 MM WASHER HEAD SCREW | 36 | 3.5 X 6 MM BOLT |
| 37 | CONTROL BOX | 38 | CONTROL WIRE | 39 | PADDLE WITH SENSOR | 40 | RUBBER BASKETBALL |

1. Please remove all components from the package and confirm that you have all parts listed.

Frame Assembly:

2. Please follow Figures 1 through 7 below to assemble the frame.

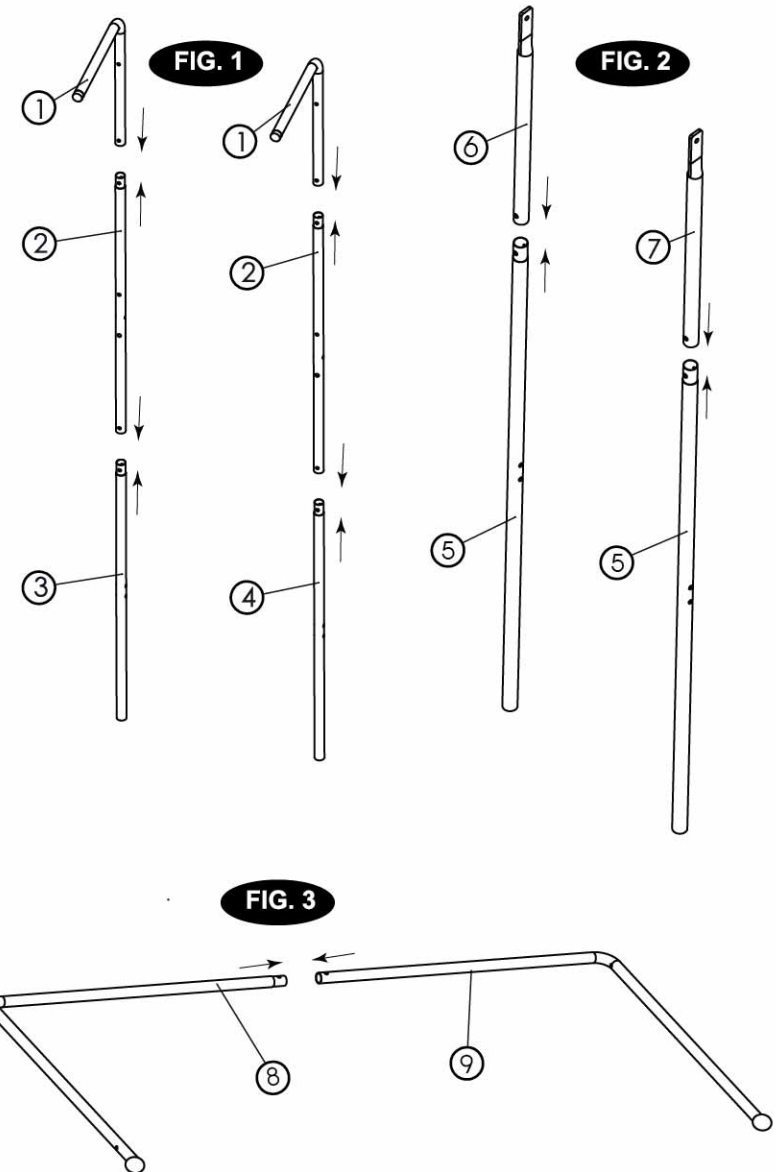

FIG. 4

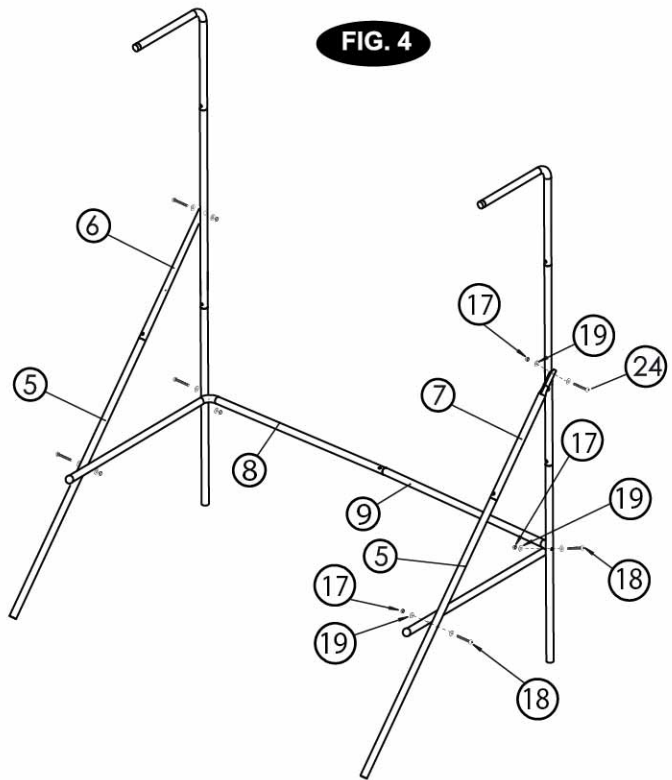

FIG. 5

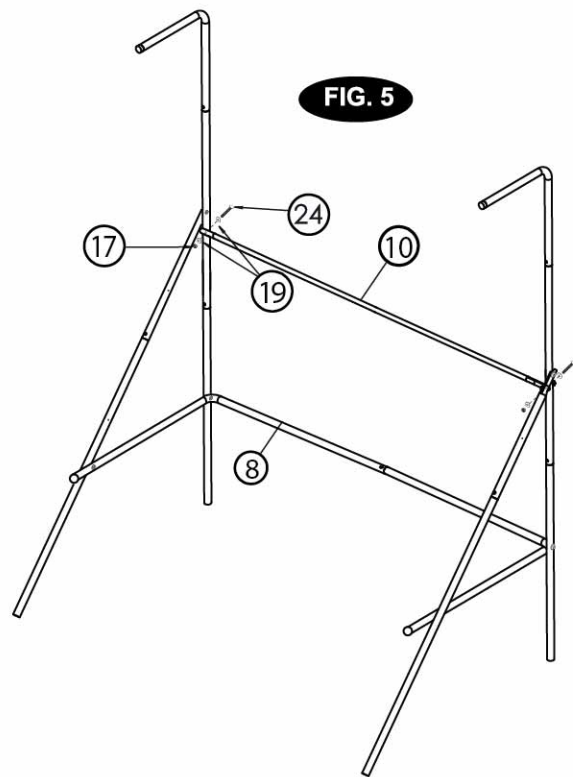

FIG. 6

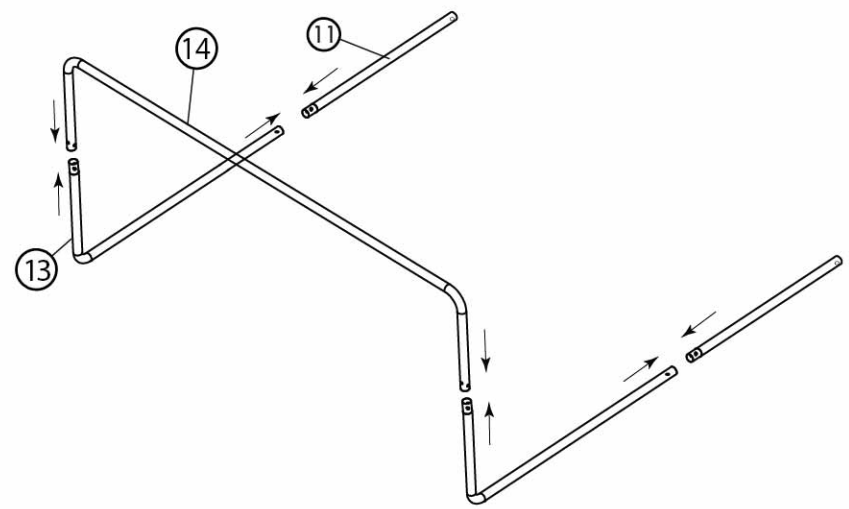
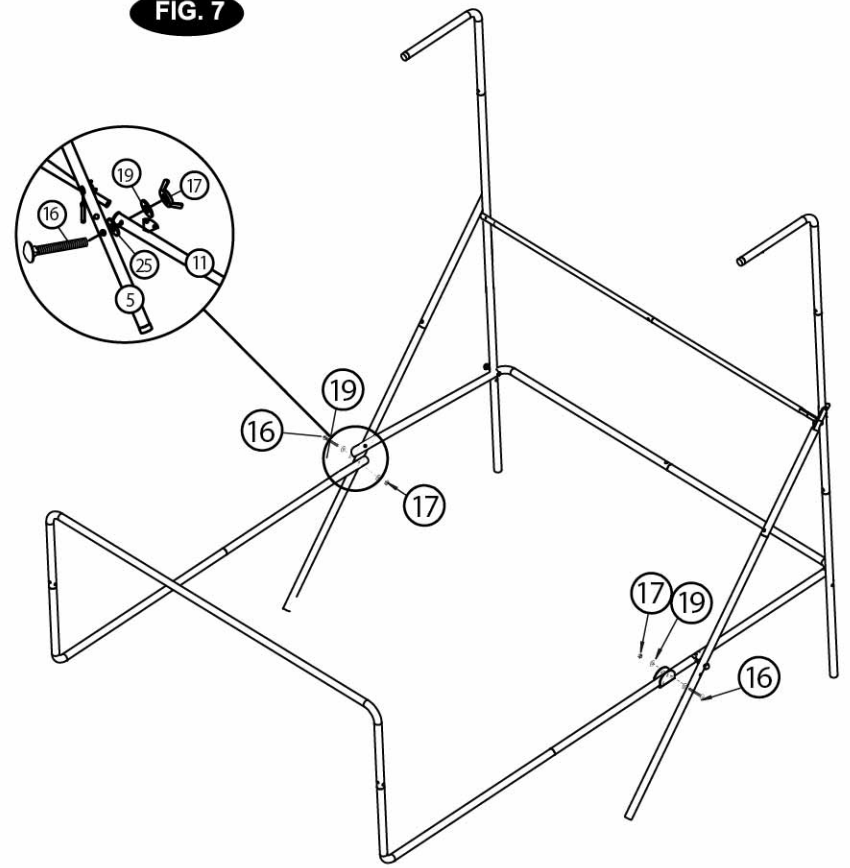

FIG. 7



Backboard Assembly:

3. Please follow Figures 8 and 9 to assemble the rims and scoring units. Follow Figures 10 and 10A to attach the backboard to the frame.

FIG. 8

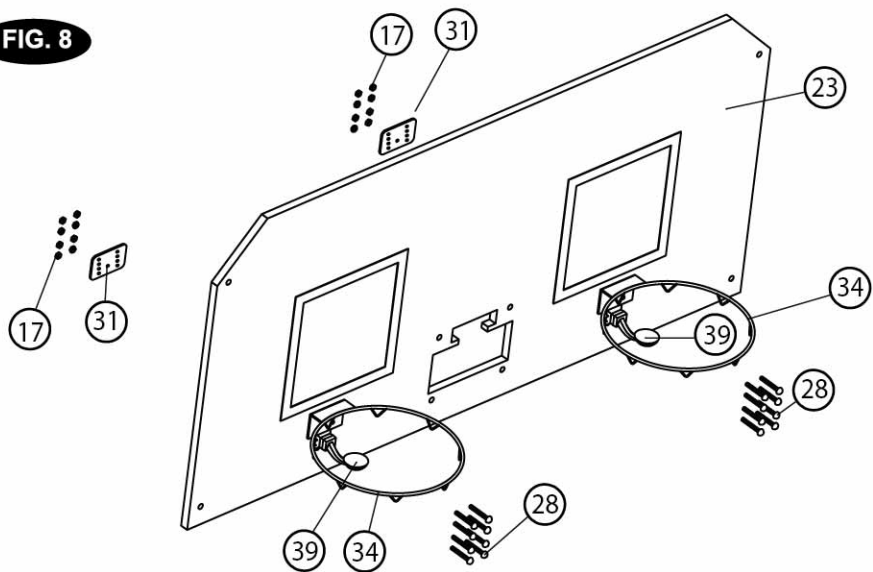

FIG. 9

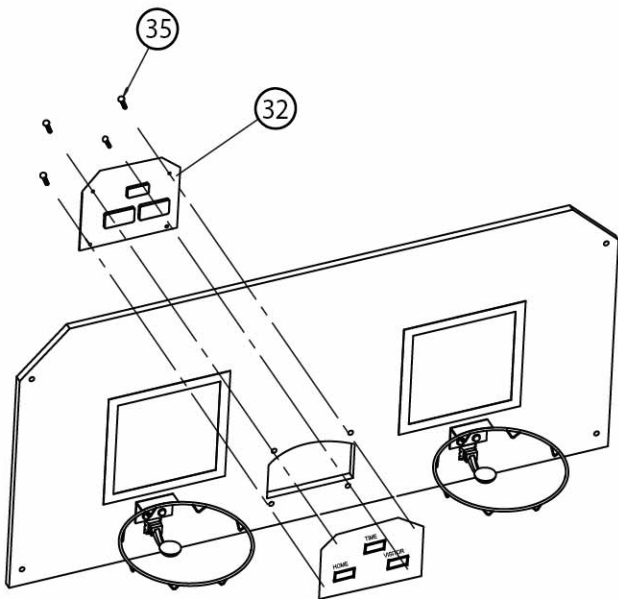

FIG. 10

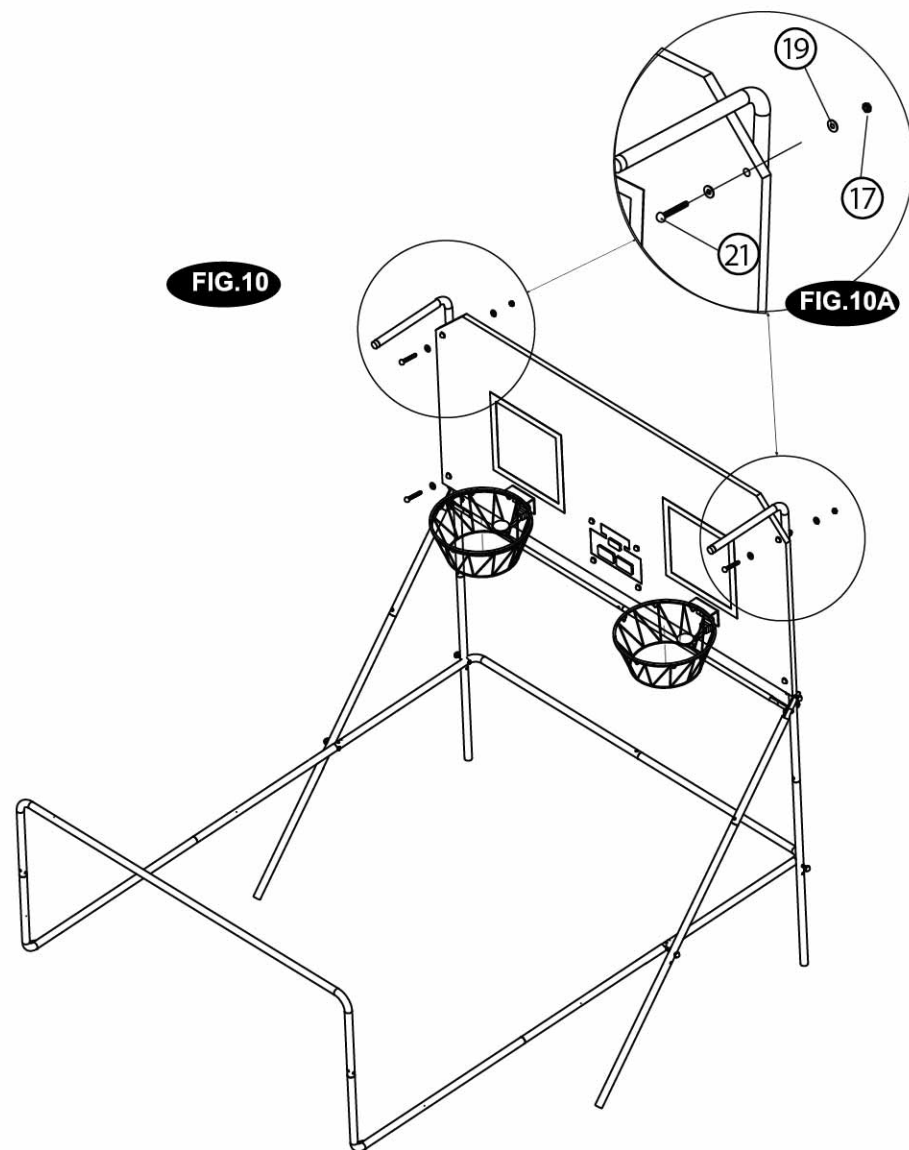
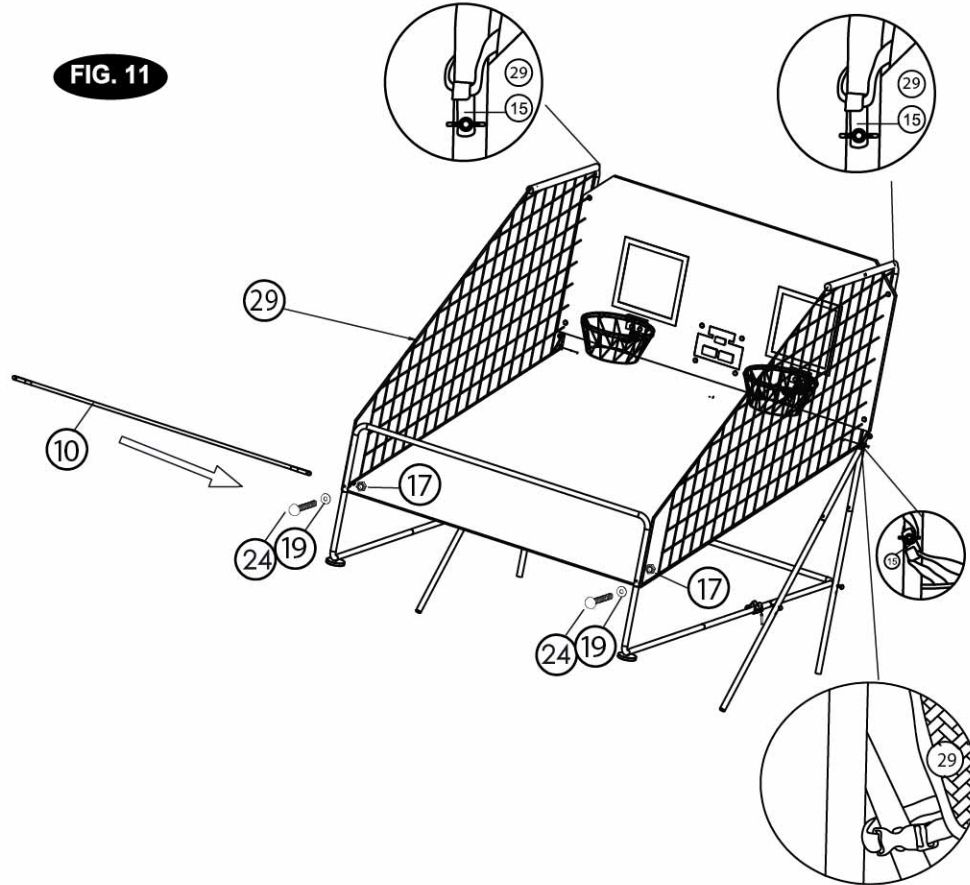

FIG. 10A

Ball Return Assembly:

4. Please see Figure 11 to assemble the ball return.



Scoring System:

4. Please see Figures 12 and 12A to assemble the scoring unit on the backboard and the frame.

FIG. 12

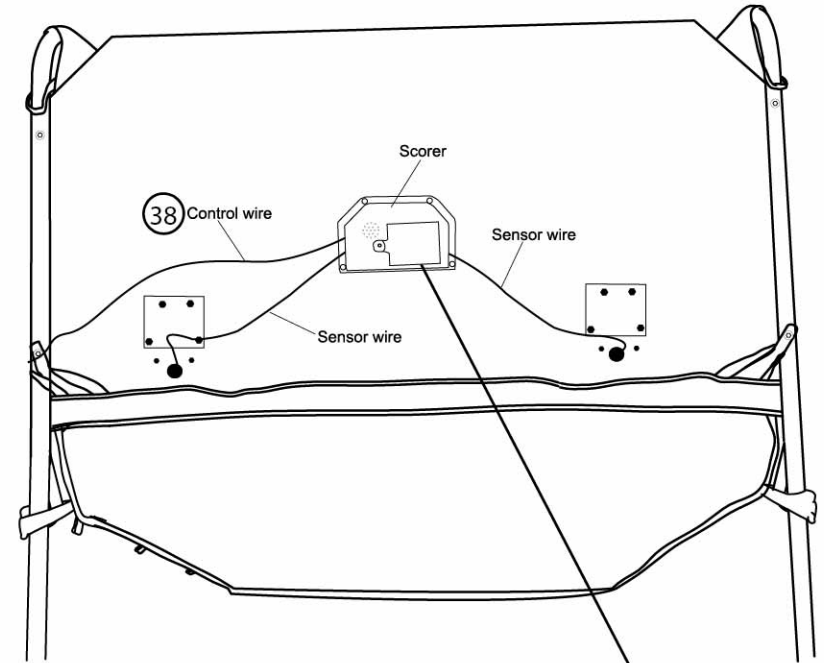

Requires 3 "AA" size batteries (not included)
Do not mix old and new batteries.
Do not mix alkaline, standard (carbon-zinc),
or rechargeable (nickel-cadmium) batteries.

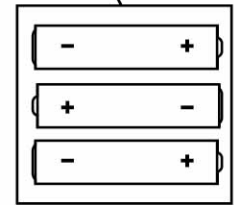
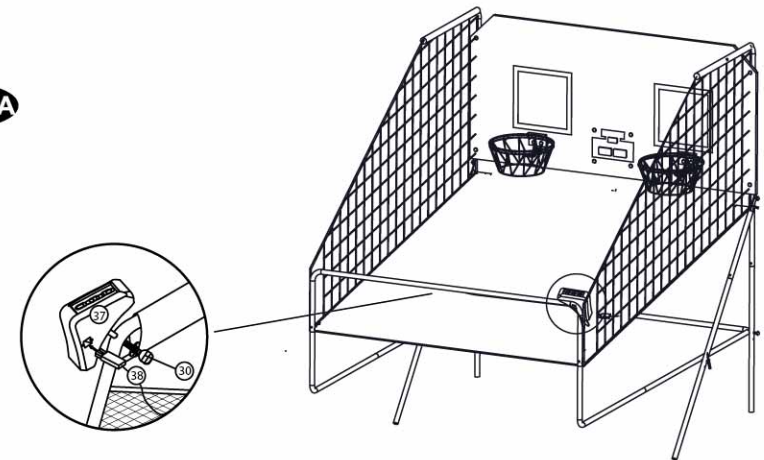

FIG. 12A



Storage:

6. Remove the locking pins from the frame joints and fold the unit for storage as shown in Figure 13.

FIG. 13

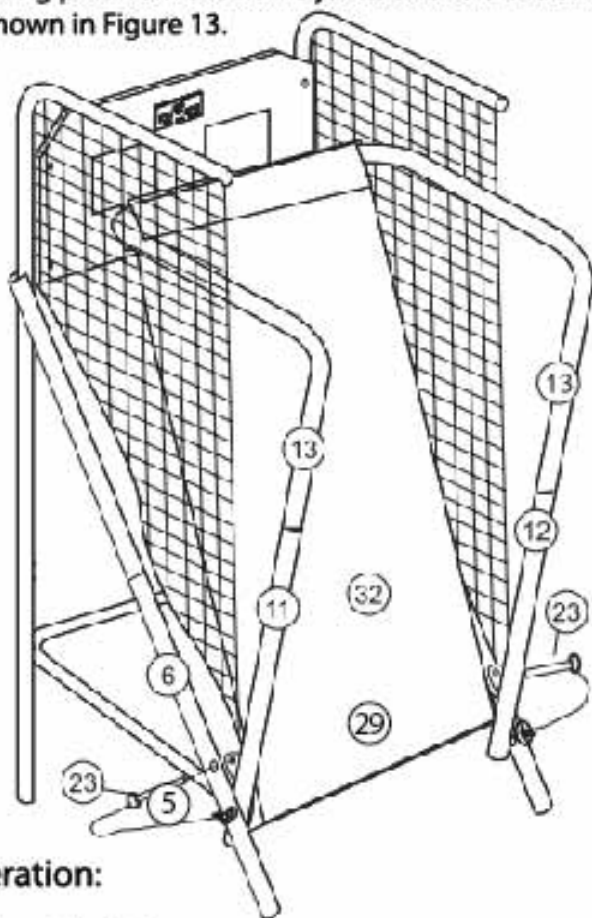

Control Box Operation:

- Press "ON/OFF" to activate the scorer
- Scoreboard "HOME" shows "01" (pre-set game 1)
- Press "Up, Down" to select a game
- Press "select" to enter selected game mode
- Press "SOUND" to switch sound on/off while playing
- Press "Pause" to pause or start time counting

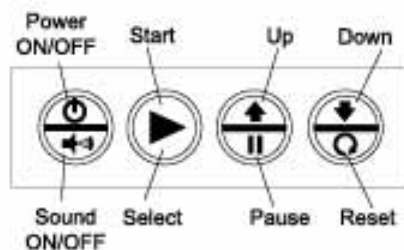

- Press and hold the button "ON/OFF" 3 seconds to turn off scorer
- Press and hold the button "RESET" 3 seconds to turn on scorer
- Note: If no shot is made or no button is pressed for 15 mins, scorer will be turned off automatically

Choose from 8 Different Game Options:

1. Beat the time Clock

- Press "PLAY" to enter game 1
- Press "UP/Down" to select single/multiple players (P1/P2/P3/P4)
- Press "PLAY" after the number of player is selected
- Press "UP/Down" to select playing time, 30/45/60 seconds
- Press "PLAY" to begin the game
- Scoreboard "Home" shows Player 1, 3; scoreboard "Visitor" shows Player 2, 4
- All shots worth 2 points until last 10 seconds, each score counts 3 points
- Countdown 5 seconds to next player's turn when one player finishes game
- Player with more points scored wins (LED will flash on player with higher score)
- Press "PLAY" to restart this game

2. 3 Point Beat the Time Clock

- Press "PLAY" to enter game 2
- Press "UP/Down" to select single/multiple players (P1/P2/P3/P4)
- Press "PLAY" after the number of player is selected
- Press "UP/Down" to select playing time, 30/45/60 seconds
- Press "PLAY" to begin the game
- Scoreboard "Home" shows Player 1, 3; scoreboard "Visitor" shows Player 2, 4
- All shots made count 3 points.
- Countdown 5 seconds to next player's turn when one player finishes game
- Player with more points scored wins (LED will flash on player with higher score)
- Press "PLAY" to restart this game

Choose from 8 Different Game Options (cont):

3. Battle Back

- Press "PLAY" to enter game 3
- Press "UP/Down" to select playing time, 30/45/60 seconds
- Press "PLAY" to begin the game
- Shot made in "HOME" frame, +2 points scored display on "HOME" board and -2 points for "Visitor"
- Shot made in "Visitor" frame, +2 points scored display on "Visitor" board and -2 points for "HOME"
- Once a player scores 10 points who wins and game is finished
- Press "PLAY" to restart this game

4. Horse

- Press "PLAY" to enter game
- Press "UP/Down" to select multiple players (P2/P3/P4)
- Press "PLAY" after the number of player is selected
- Player has to make a shot in 2 seconds.
- First player is allowed to shoot at any hoop (Home or Visitor). If first player scores in 2 seconds, no letter is given. Game continues for next player. Scoreboard will
- If player can't score in 2 seconds, player receives the first letter "H" which will display on scoreboard. Game remains for the same player until the player scores.
- The first player to spell "horse" loses. Players stay in repeat step 4.5.6. till game is finished
- The last player to spell "horse" wins
- Press "PLAY" to restart this game

5. Check Point

- Press "PLAY" to enter game 5
- Press "UP/Down" to select single/multiple players (P1/P2/P3/P4)
- Press "PLAY" to begin the game
- "HOME" displays "player", "Visitor" displays "24" points, pre-set 40 seconds playing time
- Points scored will display on scoreboard "HOME"
- Before time is out, once 24/52/68/86 points is scored, playing time increases 10/20/10/20 seconds respectively

- Countdown 5 seconds to next player's turn when one player finishes game
- Player with more points scored wins (LED will flash on player with higher score)
- Game is finished when a player scores 99 points
- Press "PLAY" to restart this game

6. Around the World

- Use tape to mark the shooting lines
- Press "PLAY" to enter game 6
- Press "UP/Down" to select single/multiple players (P1/P2/P3/P4)
- Press "PLAY" after the number of player is selected
- Scoreboard "HOME" displays Player 1/2/3/4, "Visitor" displays scored points
- Once score comes to 10 points or time comes to 99 seconds countdown 5 seconds to next player's turn when one player finishes game
- Player who finishes the game first wins (LED will flash on winner)
- Press "PLAY" to restart this game

7. Left and Right shoot

- Press "PLAY" to enter game 7
- Press "UP/Down" to select single/multiple players (P1/P2/P3/P4)
- Press "PLAY" after the number of player is selected
- Press "UP/Down" to select playing time, 30/45/60 seconds
- Press "PLAY" to begin the game
- Scoreboard "HOME" displays Player, "Visitor" displays points
- Make a shot in "HOME" frame when LED is flashing on "HOME", 2 points scored display on "HOME"
- Make a shot in "Visitor" frame when LED is flashing on "Visitor", 2 points scored display on " Visitor"
- Countdown 5 seconds to next player's turn when one player finishes game
- Player with more points scored wins (LED will flash on player with higher score)
- Press "PLAY" to restart this game