

Franklin®



55 in x 36 in (140 cm x 91.4 cm)

2-IN-1 SWITCH-HITTER®

ITEM NUMBER: **24803**

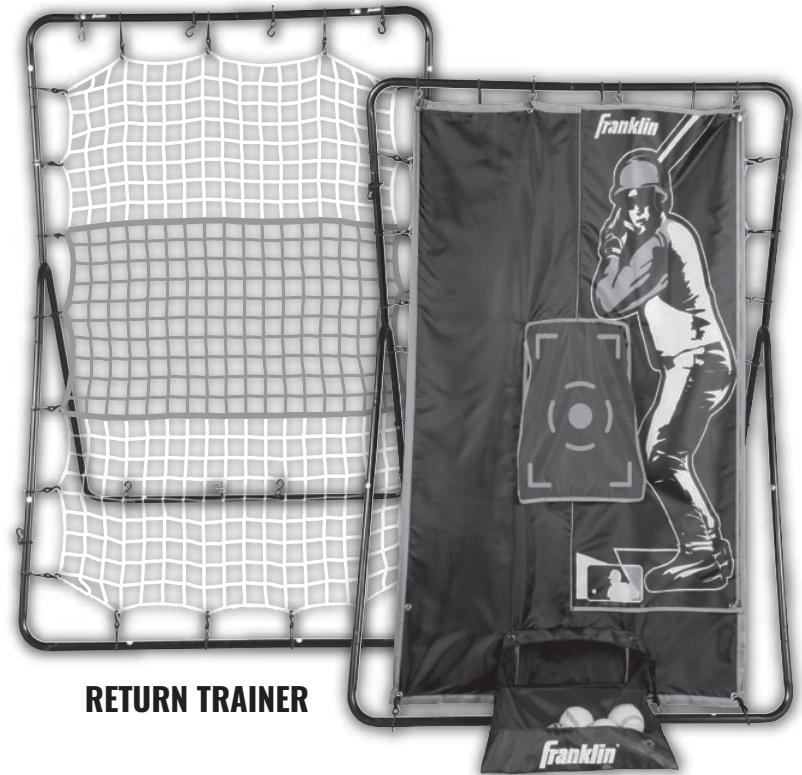

RETURN TRAINER

PITCH TARGET

Made In China
Franklin Sports Inc.
Stoughton, MA 02072



Major League Baseball trademarks
and copyrights are used with permission
of Major League Baseball. Visit MLB.com

NOTE: PRINT FRONT TO BACK

Franklin®

CUSTOMER SERVICE COMMITMENT

Thank you for purchasing this Franklin® product! In the event that the product you've purchased has missing or damaged parts, please contact us at:

parts@franklinsports.com

or

Visit our website at: franklinsports.com/instructions

If possible, please include product part number and parts description so we can best assist you.

WE'RE HERE FOR YOU!

PLEASE DO NOT RETURN THIS PRODUCT TO THE STORE IT WAS PURCHASED FROM.

WE ARE COMMITTED TO FULFILLING ALL REPLACEMENT PART NEEDS IMMEDIATELY.

Thank you for your continued support, and welcome to the #FranklinFamily!

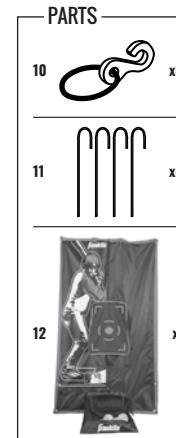
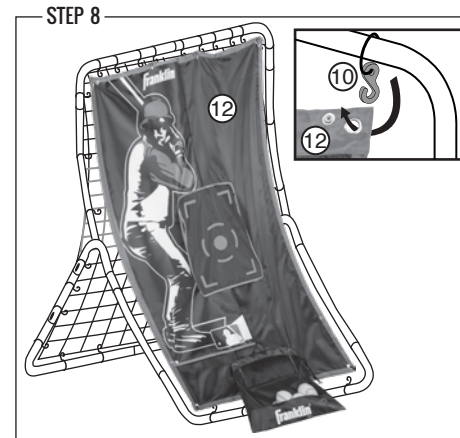

NOTE

Attach Target with Batter Graphic (#12) to 4 S-Hook Bungees (#10) at the top of the frame. Then, connect the remaining 4 S-Hook Bungees (#10) to the bottom of the Target with Batter Graphic (#12).

NOTE: Use Ground Stakes (#11) for extra stability when needed.



NOTE

The target with batter graphic can be flipped for a right-handed or left-handed batter. Snap the corners of the middle flap into place on either the right or left side of the main target area.

WARNING:

Use extreme caution when assembling the net to the frame. The bungees will be under extreme tension and must be attached carefully. Adult assembly is strongly recommended.

YOU ARE NOW READY TO PLAY!

STEP 6

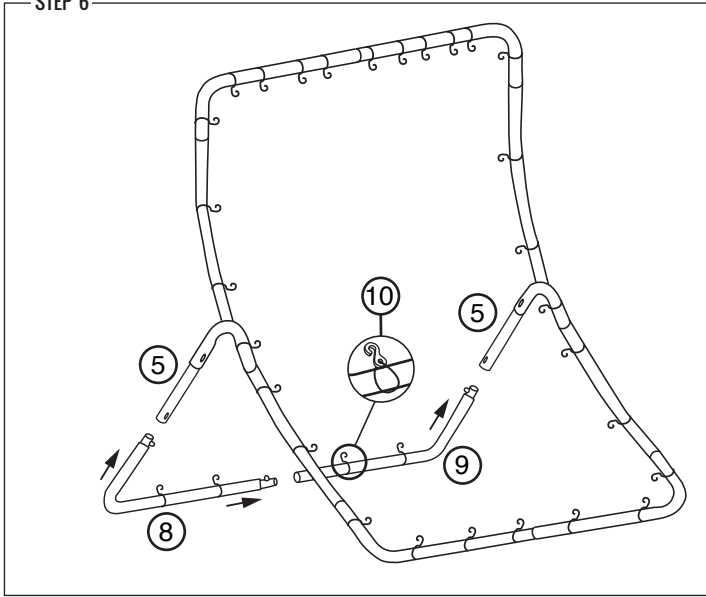

PARTS

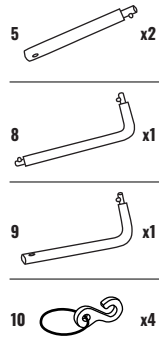

NOTE

Slide **S-Hook Bungees** (#10) onto **Left Back Bottom Elbow Tube** (#8) and **Right Back Bottom Elbow Tube** (#9). Slide **Left & Right Back Bottom Elbow Tubes** (#8 & #9) into **Back Bottom Middle Tubes** (#5). Attach **Back Bottom Elbow Poles** (#8 & #9) at the bottom to complete back of frame.

STEP 7

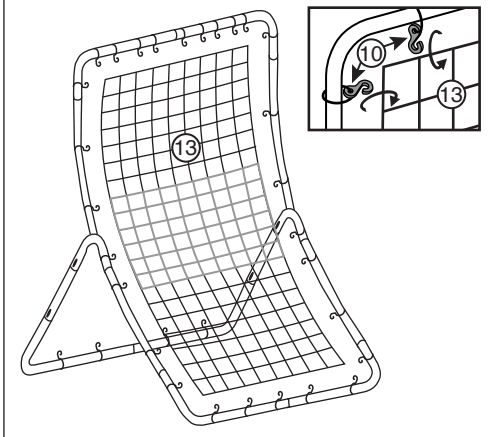

PARTS

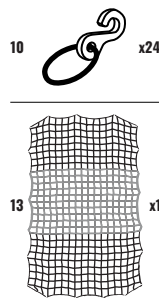

NOTE

Attach **Net with Red Integrated Strike Zone** (#13) to **S-Hook Bungees** (#10). Start at the top right corner and then attach the top left corner. Next, attach bottom right and left corners. Then, connect the remaining **S-Hook Bungees** (#10) to the net.

NOTE

Please turn frame 180° to its back side in order to attach the Switch-Hitter® target.

PARTS LIST

| | | | |
|---|--|---|--|
| 1 QTY x1 Rep Part: 19083-R1 | 2 QTY x1 Rep Part: 19083-R2 | 3 QTY x2 Rep Part: 24803-R5 | 4 QTY x2 Rep Part: 19083-R4 |
| 5 QTY x2 Rep Part: 24803-R7 | 6 QTY x1 Rep Part: 24803-R8 | 7 QTY x1 Rep Part: 24803-R9 | 8 QTY x1 Rep Part: 24803-R10 |
| 9 QTY x1 Rep Part: 24803-R11 | 10 QTY x32 Rep Part: 19083-R15 | 11 QTY x4 Rep Part: 24804-R18 | 12 QTY x1 Rep Part: 24803-R1 |
| 13 QTY x1 Rep Part: 19083-R10 | | | |

ASSEMBLY INSTRUCTIONS

GENERAL NOTE

1. Find a clean, level place to begin the assembly of your 2-in-1 Switch-Hitter®. We recommend that two adults work together to assemble this 2-in-1 Switch-Hitter®.
2. Remove all components from the package and confirm all the parts are included. Please see Step 1 to begin assembly.

STEP 1

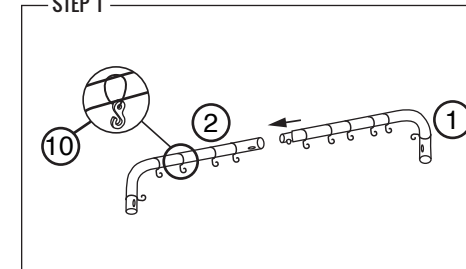

PARTS

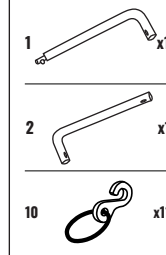

NOTE

To begin the frame, take **Elbow Tubes** (#1 & #2), slide **S-Hook Bungees** (#10) across the Tubes and attach Tubes together.

STEP 2

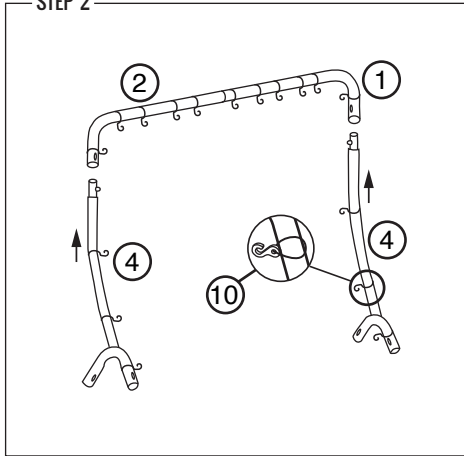

PARTS

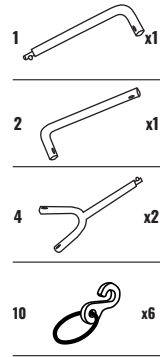

NOTE

Take "Y" Tubes (#4) and slide S-Hook Bungees (#10) along the sides and attach to Elbow Tubes (#1 & #2).

STEP 3

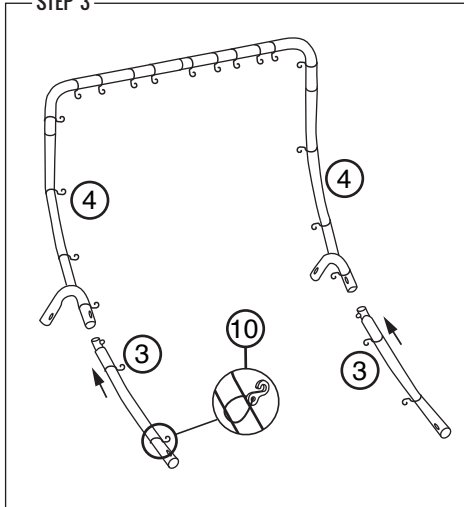

PARTS

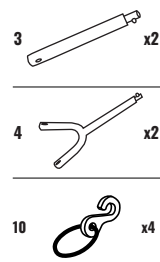

NOTE

Slide S-Hook Bungees (#10) onto Front Bottom Middle Tubes (#3), then attach to "Y" Tubes (#4).

(Note: Make sure Franklin logos are facing front on the top before attaching.)

STEP 4

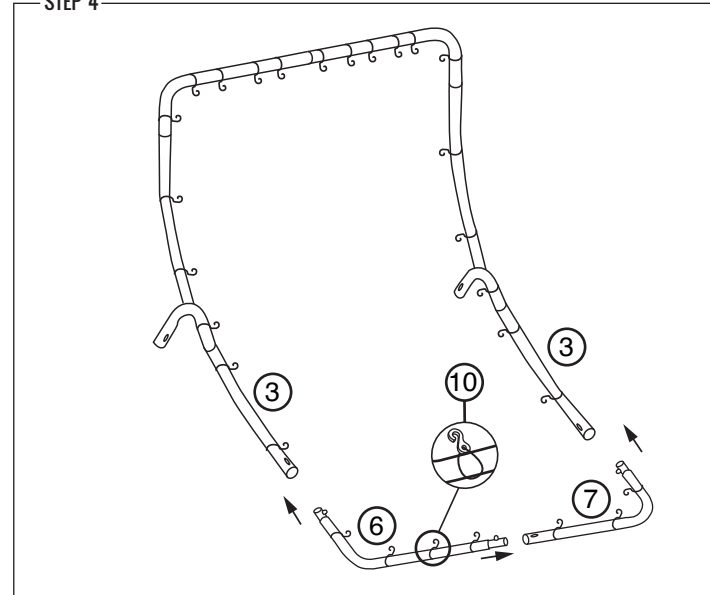

PARTS

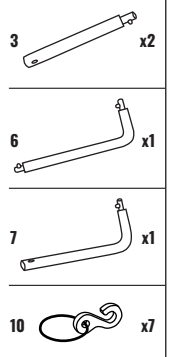

NOTE

Using Elbow Tubes (#6 & #7), slide S-Hook Bungees (#10) along poles and then insert Left Front Bottom Elbow Tube (#6) into Front Bottom Middle Tube (#3) on the left side and insert Right Front Bottom Elbow Tube (#7) into Front Bottom Middle Tubes (#3) on the right side.

STEP 5

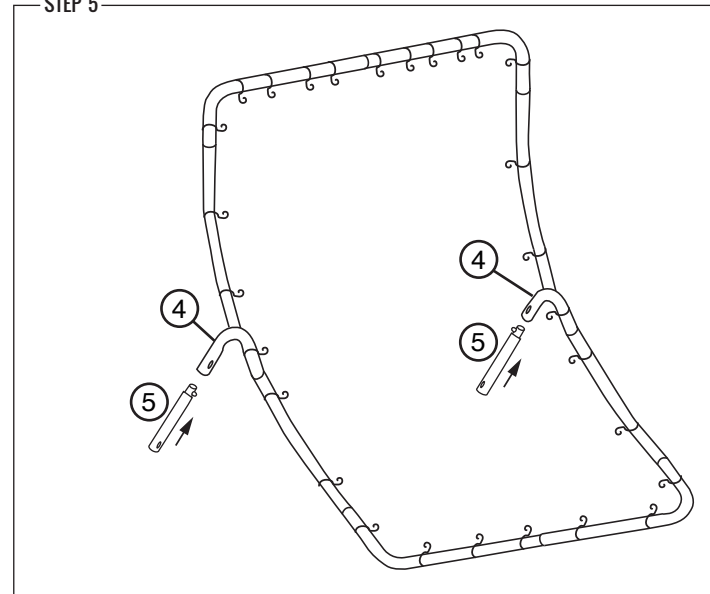

PARTS

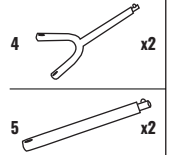

NOTE

Next, attach Back Bottom Middle Tubes (#5) to the "Y" Tubes (#4).