

# Franklin®

AGES 8+

## QUIKSET® REBOUND PRO

ITEM NUMBER: **54045**









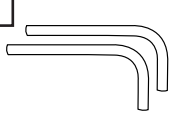
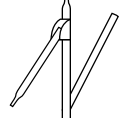
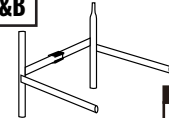
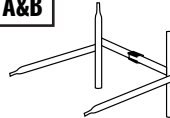
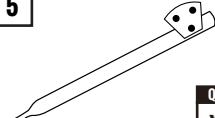
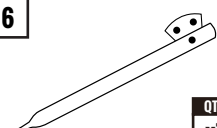
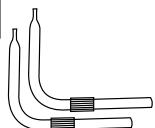
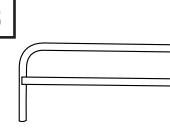
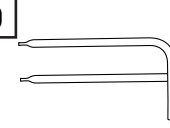

Please visit  
[www.franklinsports.com/54045](http://www.franklinsports.com/54045)  
for instructional video

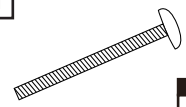
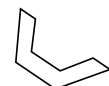
For all your replacement part needs, please visit:  
[www.franklinsports.com/54045](http://www.franklinsports.com/54045)

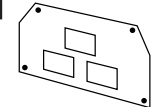
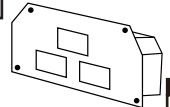
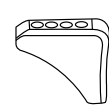

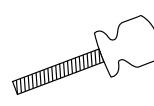
**⚠ WARNING:**  
CHOKING HAZARD--Small parts.  
Not for children under 3 yrs.  
Adult assembly required.

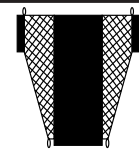
# PARTS LIST

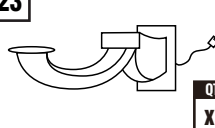
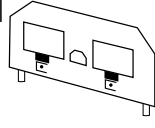
<p><b>1</b></p>  <p>QTY <b>x2</b></p> <p>Net Hanger Tube Rep. Part: 54045-R1</p>	<p><b>2</b></p>  <p>QTY <b>x2</b></p> <p>Backboard Support Tube Set Rep. Part: 54045-R2</p>	<p><b>3 A&amp;B</b></p>  <p>QTY <b>x1</b></p> <p>Base Tube Set (Left) Rep. Part: 54045-R3</p>	<p><b>4 A&amp;B</b></p>  <p>QTY <b>x1</b></p> <p>Base Tube Set (Right) Rep. Part: 54045-R4</p>	<p><b>5</b></p>  <p>QTY <b>x1</b></p> <p>Middle Ramp Tube (Right) Rep. Part: 54045-R5</p>
<p><b>6</b></p>  <p>QTY <b>x1</b></p> <p>Middle Ramp Tube (Left) Rep. Part: 54045-R6</p>	<p><b>7</b></p>  <p>QTY <b>x2</b></p> <p>Front Ramp Tube Rep. Part: 54045-R7</p>	<p><b>8</b></p>  <p>QTY <b>x1</b></p> <p>Front Horizontal Tube (Left) Rep. Part: 54045-R8</p>	<p><b>9</b></p>  <p>QTY <b>x1</b></p> <p>Front Horizontal Tube (Right) Rep. Part: 54045-R9</p>	<p><b>10</b></p>  <p>QTY <b>x4</b></p> <p>M6 Washers Rep. Part: 54045-R10</p>
<p><b>11</b></p>  <p>QTY <b>x3</b></p> <p>M6 Screw Set (60mm x2, 33mm x1) Rep. Part: 54045-R11</p>	<p><b>12</b></p>  <p>QTY <b>x3</b></p> <p>M6 Wing Nut Rep. Part: 54045-R12</p>	<p><b>13</b></p>  <p>QTY <b>x2</b></p> <p>Lock Pin Rep. Part: 54045-R13</p>	<p><b>14</b></p>  <p>QTY <b>x1</b></p> <p>Electronic Scorer Face Plate Rep. Part: 54045-R14</p>	<p><b>15</b></p>  <p>QTY <b>x1</b></p> <p>Electronic Scorer Rep. Part: 54045-R15</p>
<p><b>16</b></p>  <p>QTY <b>x1</b></p> <p>Control Box Rep. Part: 54045-R16</p>	<p><b>17</b></p>  <p>QTY <b>x2</b></p> <p>Rim with Net Rep. Part: 54045-R17</p>	<p><b>18</b></p>  <p>QTY <b>x1</b></p> <p>Control Box Screw Rep. Part: 54045-R18</p>	<p><b>19</b></p>  <p>QTY <b>x1</b></p> <p>Inflating Pump and Needle Rep. Part: 54045-R19</p>	<p><b>20</b></p>  <p>QTY <b>x4</b></p> <p>Rubber Basketball Rep. Part: 54045-R20</p>
<p><b>21</b></p>  <p>QTY <b>x1</b></p> <p>Ball Return Net Rep. Part: 54045-R21</p>	<p><b>22</b></p>  <p>QTY <b>x1</b></p> <p>Control Wire Rep. Part: 54045-R22</p>	<p><b>23</b></p>  <p>QTY <b>x2</b></p> <p>Paddle with Sensor Rep. Part: 54045-R23</p>	<p><b>24</b></p>  <p>QTY <b>x1</b></p> <p>Backboard Rep. Part: 54045-R24</p>	

# ASSEMBLY INSTRUCTIONS

## GENERAL NOTE

1. Find a clean, level place to begin the assembly of your Quickset® Rebound Pro. We recommend that two adults work together to assemble this Quickset® Rebound Pro.
2. Remove all the parts from the box and verify that you have all of the listed parts as shown on the parts list page. Carefully cut or tear the four corners of the box so that the bottom of the box can be used as your work surface.

## STEP 1

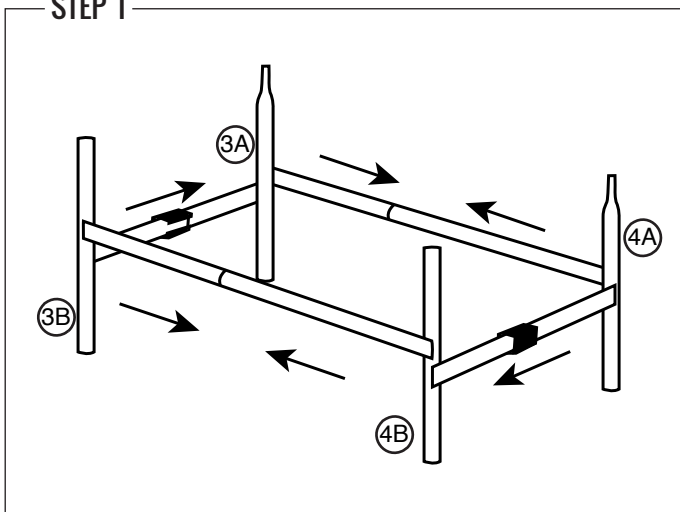

## PARTS

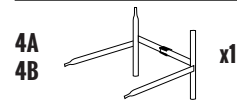
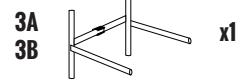

## NOTE

Connect the **Base Tube Set (Left)** (#3 A&B) to the **Base Tube Set (Right)** (#4 A&B). Slide the pre-assembled locking brace directly over the center of where the 2 hinges connect.

## STEP 2

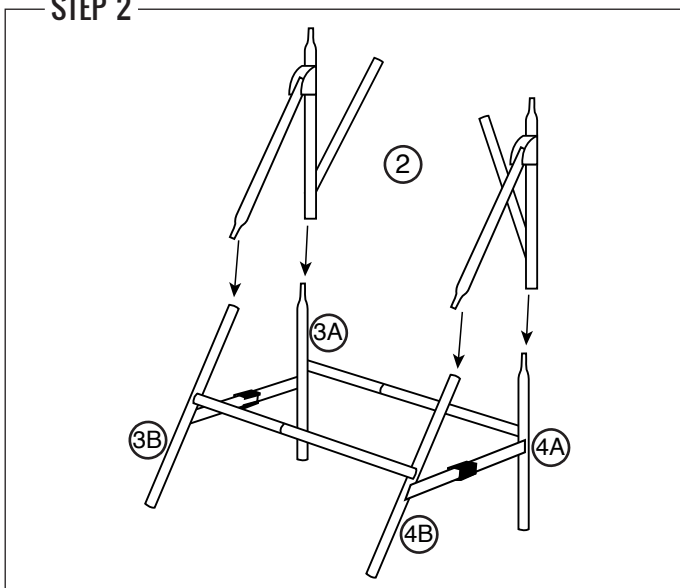

## PARTS

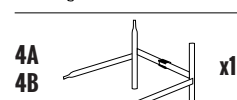
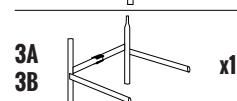

## NOTE

Connect the **Backboard Support Tube Set** (#2) to the tops of the base (#3 and #4).

**STEP 3**

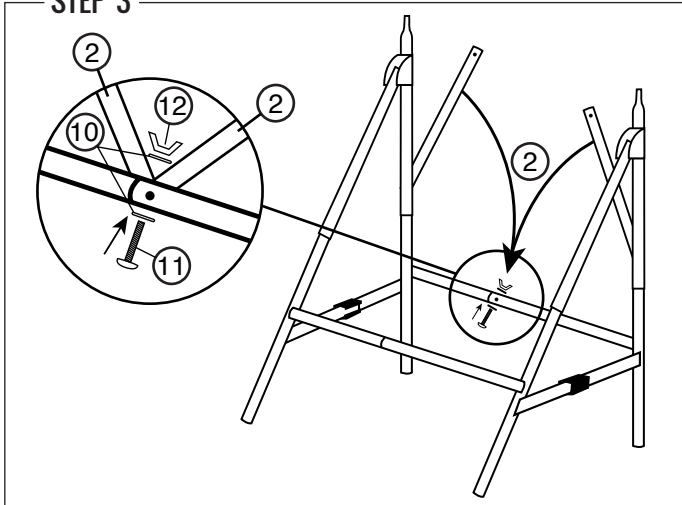

**PARTS**

2		x2
10		x2
11		x1
12		x1

**NOTE**

Connect the back tubes of the **Backboard Support Tube Sets (#2)** to the back horizontal tube of the base using **M6 Washers (#10)**, **33mm M6 Bolt (#11)** and **M6 Wing Nut (#12)**.

**STEP 4**

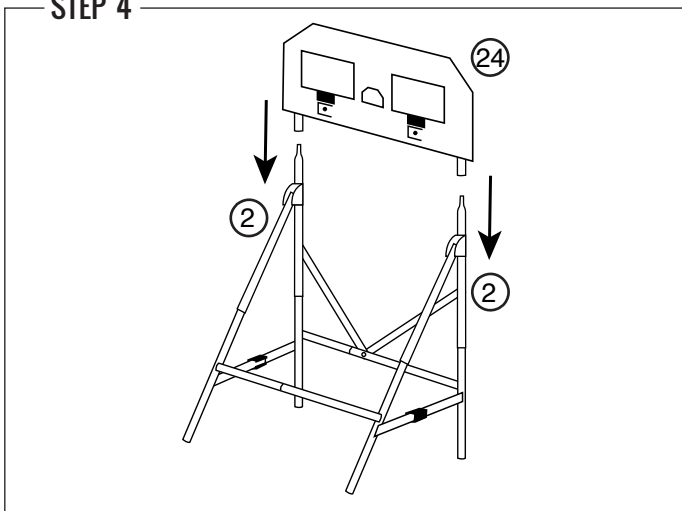

**PARTS**

2		x2
24		x1

**NOTE**

Connect the **Backboard (#24)** to the **Backboard Support Tubes Sets (#2)**.

**STEP 5**

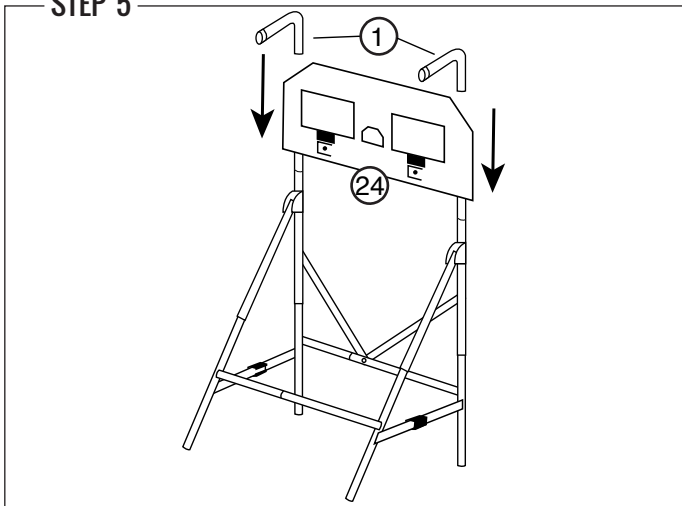

**PARTS**

1		x2
24		x1

**NOTE**

Connect the **Net Hanger Tubes (#1)** to the **Backboard (#24)**.

**STEP 6**

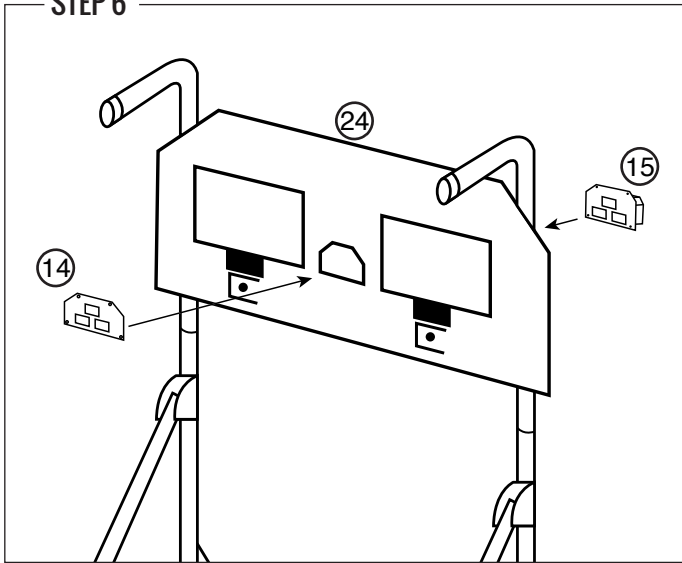

**PARTS**

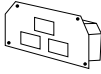
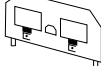
14		x1
15		x1
24		x1

**NOTE**

Connect the **Electronic Scorer Face Plate (#14)** and **Electronic Scorer (#15)** by inserting the face plate rivets through the front of the **Backboard (#24)** and snapping into the electronic scorer.



**NOTE**

Requires 3 "AA" size batteries (not included).  
Do not mix old and new batteries.  
Do not mix alkaline, standard (carbon-zinc), or rechargeable (nickel-cadmium) batteries.

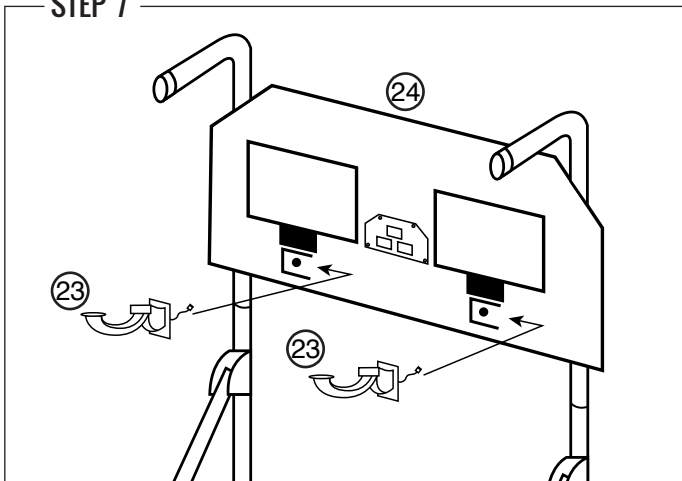
**STEP 7**

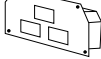

**PARTS**

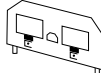
15		x1
23		x2
24		x1

**NOTE**

Attach the **Paddles with Sensors (#23)** to the **Backboard (#24)** by inserting the paddle wires through the holes in the backboard and sliding the paddle backs to the left through the grooves. Plug in the paddle wires into the **Electronic Scorer (#15)**.

**STEP 8**

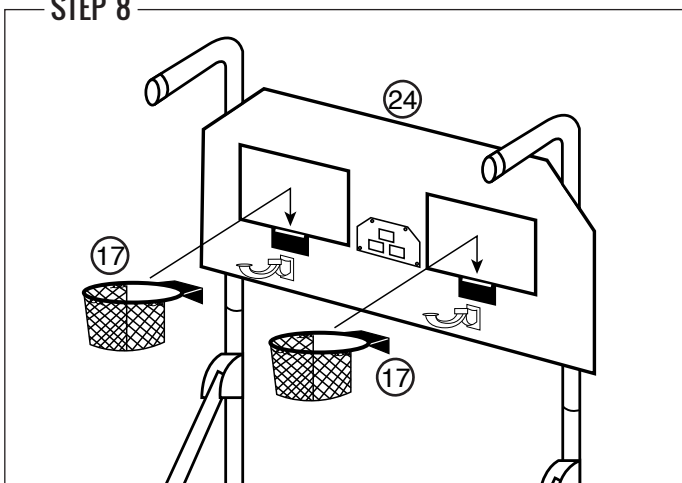

**PARTS**

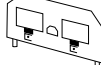
17		x2
24		x1

**NOTE**

Slide the back of the **Rim with Net (#17)** into the brackets on the **Backboard (#24)**.

**STEP 9**

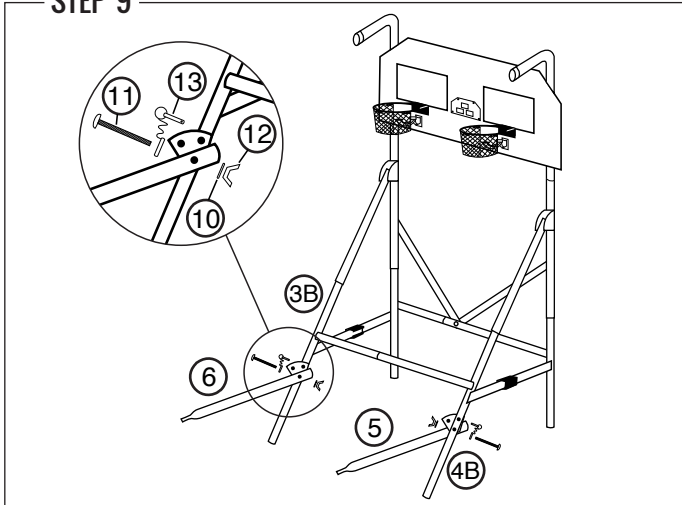

**PARTS**

5		x1
6		x1
10		x2
11		x2
12		x2
13		x2

**NOTE**

Attach the **Middle Ramp Tube (Right) (#5)** and the **Middle Ramp Tube (Left) (#6)** to the base using **M6 Bolts (#11)**, **Lock Pins (#13)**, **M6 Washers (#10)**, and **M6 Wing Nut (#12)**. Insert the lock pins through the base and ramp tube.

**STEP 10**

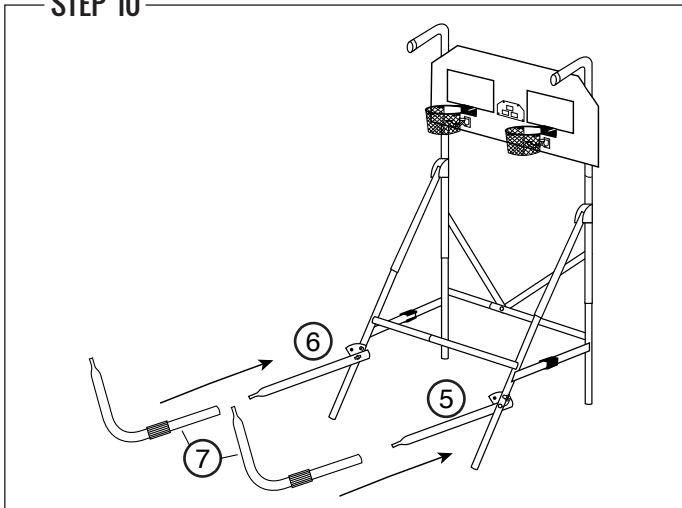

**PARTS**

5		x1
6		x1
7		x2

**NOTE**

Attach the **Front Ramp Tubes (#7)** to the **Middle Ramp Tube (Right) (#5)** and the **Middle Ramp Tube (Left) (#6)**.

**STEP 11**

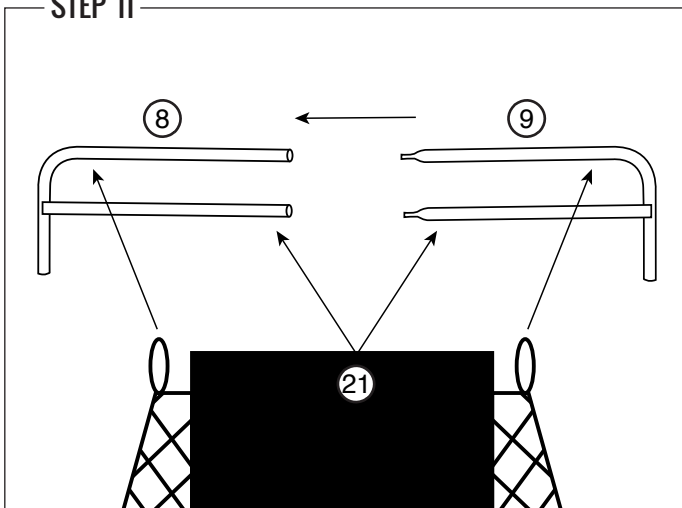

**PARTS**

8		x1
9		x1
21		x1

**NOTE**

Slide the **Front Horizontal Tubes (Right) (#9)** through the sleeve (bottom tube) and elastics (top tube) of the **Ball Return Net (#21)**. Connect the **Front Horizontal Tubes (Right) (#9)** to the **Front Horizontal Tubes (Left) (#8)** and spread out net.

**STEP 12**

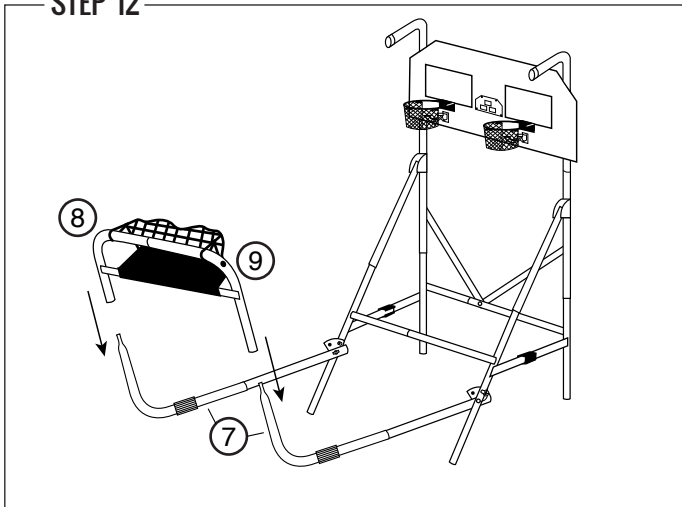

**PARTS**

7		x2
8		x1
9		x1

**NOTE**

Connect the **Front Horizontal Tubes (Right) (#9)** and the **Front Horizontal Tubes (Left) (#8)** to the **Front Ramp Tubes (#7)**.

**STEP 13**

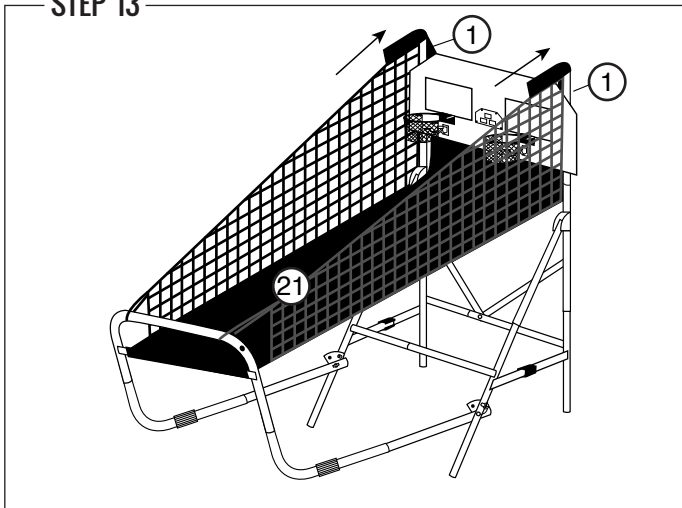

**PARTS**

1		x2
21		x1

**NOTE**

Slide the **Net Hanger Tubes (#1)** into the top sleeves of the **Ball Return Net (#21)**. Wrap elastic net supports around wing nuts found behind the backboard.

**STEP 14**

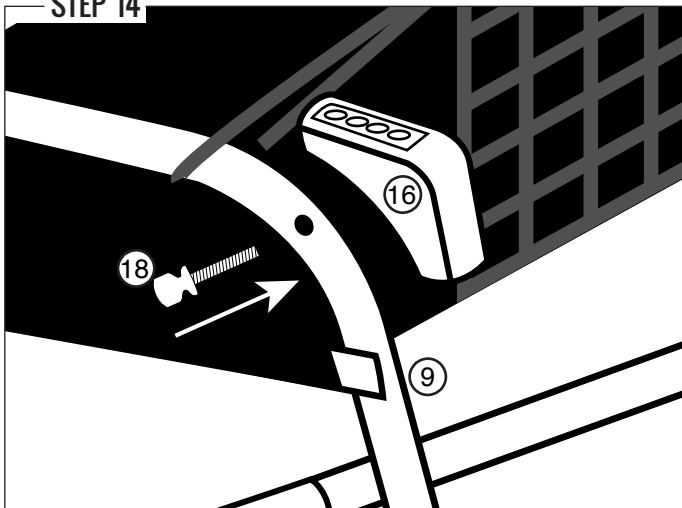

**PARTS**

9		x1
16		x1
18		x1



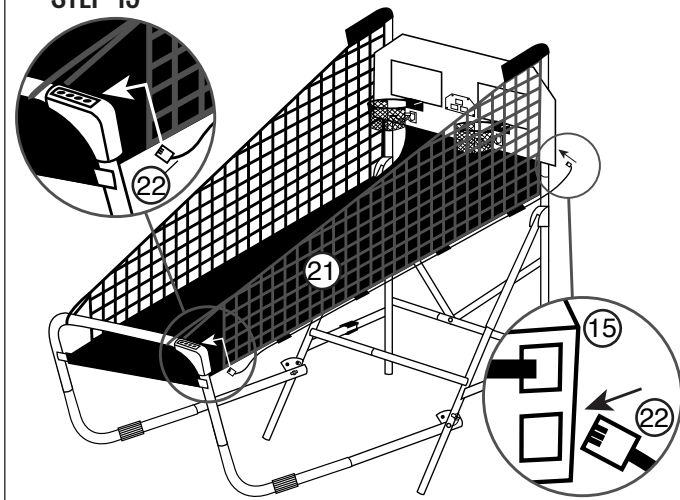

**NOTE**

Attach the **Control Box (#16)** to the **Front Horizontal Tubes (Right) (#9)** using the **Control Box Screw (#18)**.

**STEP 15**

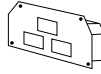

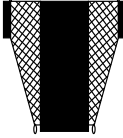
**PARTS**

15		x1
16		x1
21		x1
22		x1



**NOTE**

Plug the bigger end of the **Control Wire (#22)** into the **Control Box (#16)**. Run the wire through the support loops on the side of the **Ball Return Net (#21)**. Plug the smaller end of the wire into the **Electronic Scorer (#15)**.

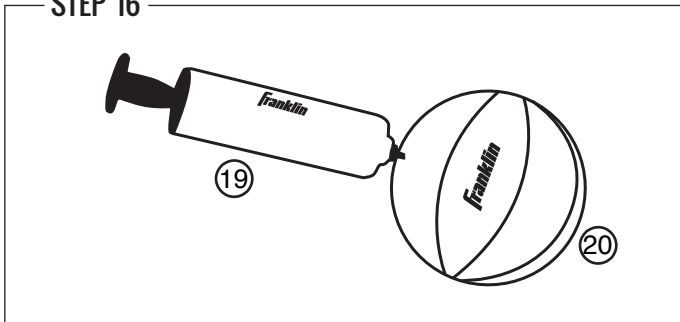
**STEP 16**



**PARTS**

19		x1
20		x4

**NOTE**



Inflate the **Rubber Basketballs (#20)** with the **Inflating Pump and Needle (#19)**.

**YOU ARE NOW READY TO PLAY!**

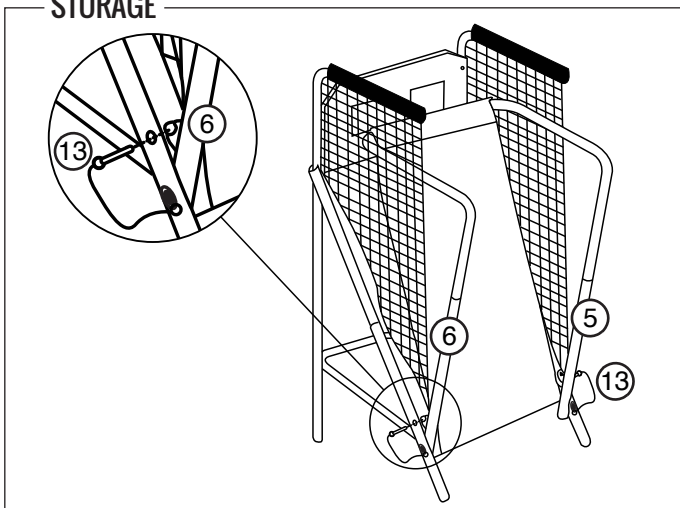
**STORAGE**



**PARTS**

5		x1
6		x1
13		x2

**NOTE**

Remove the **Lock Pin (#13)** from both sides of the base. Fold up the front of the ball return. Line up the holes in the base tubes and the **Middle Ramp Tubes (#5 and #6)**. Insert the pin through the holes.

# GAME INSTRUCTIONS

## Control Box Operation

- **PRESS "ON/OFF" TO ACTIVATE THE CONTROL BOX (HOLD FOR 5 SECONDS)**

- Scoreboard "HOME" shows "01" (pre- set game 1)
- Press "Up, Down" to select a game
- Press "select" to enter selected game mode
- Press "SOUND" to switch sound on/off while playing
- Press "Pause" to pause or start time counting
- Press and hold the button "ON/OFF" 3 seconds to turn off control box
- Press and hold the button "RESET" 3 seconds to turn on control box

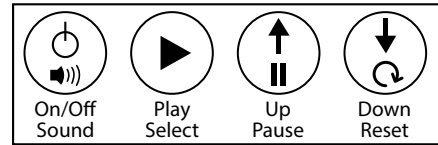

Note: If no shot is made or no button is pressed for 15 mins, control box will be turned off automatically

## 1. Beat the Time Clock

- Press "PLAY" to enter game 1
- Press "UP/Down" to select single/multiple players (P1/P2/P3/P4)
- Press "PLAY" after the number of player is selected
- Press "UP/Down" to select playing time, 30/45/60 seconds
- Press "PLAY" to begin the game
- Scoreboard "Home" shows Player 1, 3; scoreboard "Visitor" shows Player 2, 4
- All shots worth 2 points until last 10 seconds, each score counts 3 points
- Countdown 5 seconds to next player's turn when one player finishes game
- Player with more points scored wins ( LED will flash on player with higher score)
- Press "PLAY" to restart this game

## 2. 3 Point Beat the Time Clock

- Press "PLAY" to enter game 2
- Press "UP/Down" to select single/multiple players (P1/P2/P3/P4)
- Press "PLAY" after the number of player is selected
- Press "UP/Down" to select playing time, 30/45/60 seconds
- Press "PLAY" to begin the game
- Scoreboard "Home" shows Player 1, 3; scoreboard "Visitor" shows Player 2, 4
- All shots made count 3 points.
- Countdown 5 seconds to next player's turn when one player finishes game
- Player with more points scored wins (LED will flash on player with higher score)
- Press "PLAY" to restart this game

## 3. Battle Back

- Press "PLAY" to enter game 3
- Press "UP/DOWN" to select players (2P/4P)
- Press "PLAY" to begin the game
- Shot made in "HOME" frame, +2 points scored display on "HOME" board and -2 points for "Visitor"
- Shot made in "Visitor" frame, +2 points scored display on "Visitor" board and -2 points for "HOME"
- Once a player scores 10 points who wins and game is finished
- Press "PLAY" to restart this game

# GAME INSTRUCTIONS CONTINUED

## 4. Horse

- Press "PLAY" to enter game
- Press "UP/Down" to select multiple players (P2/P3/P4)
- Press "PLAY" after the number of player is selected
- Player has to make a shot in 2 seconds.
- First player is allowed to shoot at any hoop (Home or Visitor). If first player scores in 2 seconds, no letter is given. Game continues for next player.
- If player can't score in 2 seconds, player receives the first letter "H" which will display on scoreboard. Game remains for the same player until the player scores.
- The first player to spell "horse" loses. Players stay in repeat step 4.5.6. till game is finished
- The last player to spell "horse" wins
- Press "PLAY" to restart this game

## 5. Check Point

- Press "PLAY" to enter game 5
- Press "UP/Down" to select single/multiple players (P1/P2/P3/P4)
- Press "PLAY" to begin the game
- "HOME" displays "player", "Visitor" displays "24" points, pre-set 40 seconds playing time
- Points scored will display on scoreboard "HOME"
- Before time is out, once 24/52/68/86 points is scored, playing time increases 10/20/10/20 seconds respectively
- Countdown 5 seconds to next player's turn when one player finishes game
- Player with more points scored wins ( LED will flash on player with higher score)
- Game is finished when a player scores 98 points
- Press "PLAY" to restart this game

## 6. Around the World

- Use tape to mark the shooting lines
- Press "PLAY" to enter game 6
- Press "UP/Down" to select single/multiple players (P1/P2/P3/P4)
- Press "PLAY" after the number of player is selected
- Scoreboard "HOME" displays Player 1/2/3/4, "Visitor" displays scored points
- Once score comes to 10 points or time comes to 99 seconds countdown 5 seconds to next player's turn when one player finishes game
- Player who finishes the game first wins (LED will flash on winner)
- Press "PLAY" to restart this game

## 7. Left and Right shoot

- Press "PLAY" to enter game 7
- Press "UP/Down" to select single/multiple players (P1/P2/P3/P4)
- Press "PLAY" after the number of player is selected
- Press "UP/Down" to select playing time, 30/45/60 seconds
- Press "PLAY" to begin the game
- Scoreboard "HOME" displays Player, "Visitor" displays points
- Make a shot in "HOME" frame when LED is flashing on "HOME", 2 points scored display on "HOME"
- Make a shot in "Visitor" frame when LED is flashing on "Visitor", 2 points scored display on " Visitor"
- Countdown 5 seconds to next player's turn when one player finishes game
- Player with more points scored wins ( LED will flash on player with higher score)
- Press "PLAY" to restart this game

# GAME INSTRUCTIONS CONTINUED

## 8. One to One

- Press "PLAY" to enter game 8
- Press "UP/Down" to select single/multiple players(1P/2P/3P/4P)
- Press "PLAY" after the number of player is selected.
- Press "UP/Down" to select playing time, 30/45/60 seconds
- Press "PLAY" to begin the game
- Shot made in "HOME" frame, 2 points scored for "HOME", all shots count 3 points in last 10 seconds
- Shot made in "Visitor" frame, 2 points scored for "Visitor", all shots count 3 points in last 10 seconds
- Player with more points scored wins when time is out
- Press "PLAY" to restart this game

CHANGES OR MODIFICATIONS NOT EXPRESSLY APPROVED BY THE PARTY RESPONSIBLE FOR COMPLIANCE COULD VOID THE USER'S AUTHORITY TO OPERATE THE EQUIPMENT.

**NOTE:** THE EQUIPMENT HAS BEEN TESTED AND FOUND TO COMPLY WITH THE LIMITS FOR A CLASS B DIGITAL DEVICE; PURSUANT TO PART 15 OF THE FCC RULES. THESE LIMITS ARE DESIGNED TO PROVIDE REASONABLE PROTECTION AGAINST HARMFUL INTERFERENCE IN A RESIDENTIAL INSTALLATION. THIS EQUIPMENT GENERATES, USES AND CAN RADIATE RADIO FREQUENCY ENERGY AND, IF NOT INSTALLED AND USED IN ACCORDANCE WITH THE INSTRUCTIONS, MAY CAUSE HARMFUL INTERFERENCE TO RADIO COMMUNICATIONS. HOWEVER, THERE IS NO GUARANTEE THAT INTERFERENCE WILL NOT OCCUR IN A PARTICULAR INSTALLATION. IF THIS EQUIPMENT DOES CAUSE HARMFUL INTERFERENCE TO RADIO OR TELEVISION RECEPTION, WHICH CAN BE DETERMINED BY TURNING THE EQUIPMENT OFF AND ON, THE USER IS ENCOURAGED TO TRY TO CORRECT THE INTERFERENCE BY ONE OR MORE OF THE FOLLOWING MEASURES:

- REORIENT OR RELOCATE THE RECEIVING ANTENNA.
- INCREASE THE SEPARATION BETWEEN THE EQUIPMENT AND RECEIVER.
- CONNECT THE EQUIPMENT INTO AN OUTLET ON A CIRCUIT DIFFERENT FROM THAT TO WHICH THE RECEIVER IS CONNECTED.
- CONSULT THE DEALER OR AN EXPERIENCE RADIO/TV TECHNICIAN FOR HELP.