

Franklin®

AGES 8+

QUIKSET®

BASKETBALL

ITEM NUMBER: **54058X**

Please visit
www.franklinsports.com/54058X
for instructional video



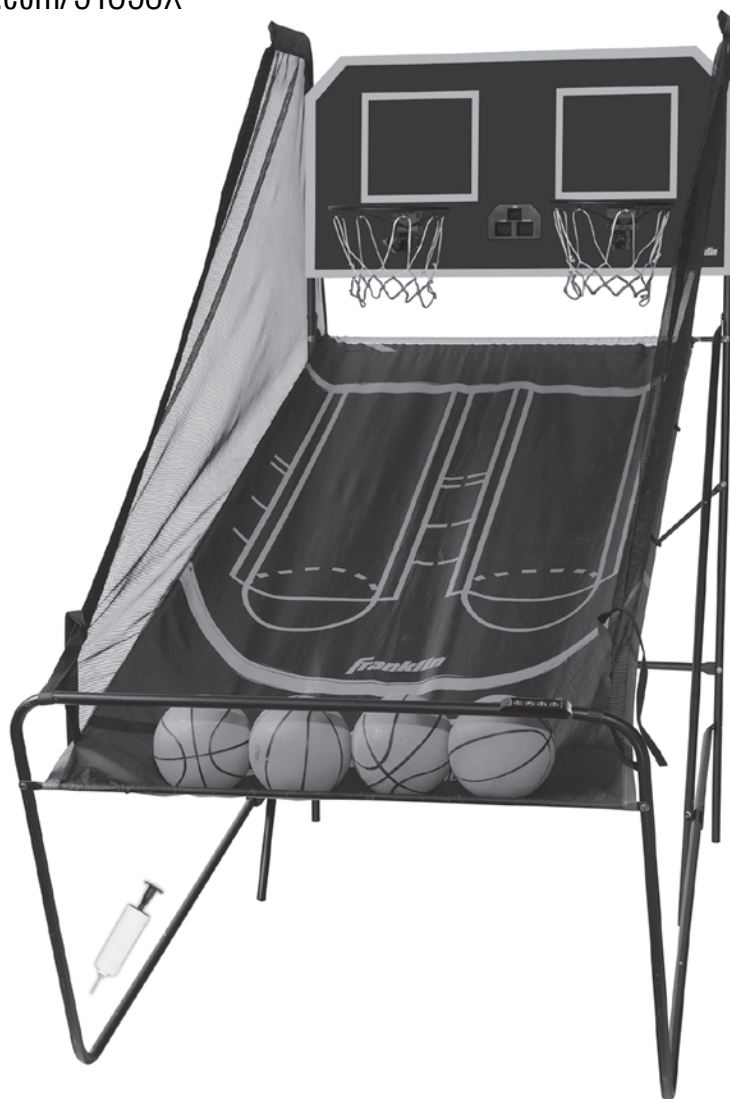









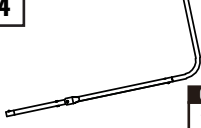
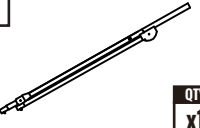
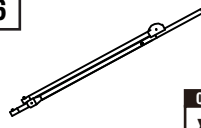

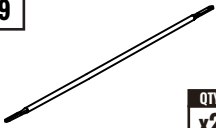

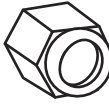
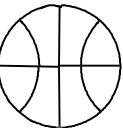
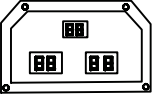
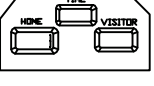
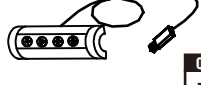
For all your replacement part needs, please visit:
www.franklinsports.com/54058X

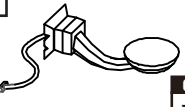
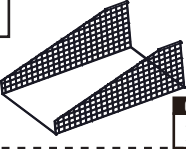
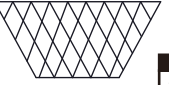
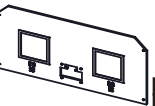

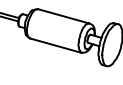

WARNING:

CHOKING HAZARD--Small parts.
Not for children under 3 yrs.
Adult assembly required.

PARTS LIST

1  #1 Sub-Assembly (Left) 54058-R1 QTY x1	2  #1 Sub-Assembly (Right) 54058-R2 QTY x1	3  #2 Sub-Assembly (Left) 54058-R3 QTY x1	4  #2 Sub-Assembly (Right) 54058-R4 QTY x1	5  #3 Sub-Assembly (Left) 54058-R5 QTY x1
6  #3 Sub-Assembly (Right) 54058-R6 QTY x1	7  L-Tube 54058-R7 QTY x2	8  U-Tube 54058-R8 QTY x1	9  1/2" Horizontal Bar 54058-R9 QTY x2	10  M6 x 38mm Bolts 54058-R10 QTY x9
11  #6 x 22mm Bolts 54058-R11 QTY x16	12  Nut 54058-R12 QTY x27	13  Orange Basketball 54058-R13 QTY x4	14  Electronic Scorer 54058-R14 QTY x1	15  Electronic Scorer Face Plate 54058-R15 QTY x1
16  Control Box 54058-R16 QTY x1	17  Locking Pin 54058-R17 QTY x2	18  Triggering Paddle 54058-R18 QTY x2	19  Ball Return 54058X-R19 QTY x1	20  Net 54058-R20 QTY x2
21  Backboard 54058X-R21 QTY x1	22  Basketball Rim 54058-R22 QTY x2	23  Pump 54058-R23 QTY x1	24  3.5 x 12 Wood Screw 54058-R24 QTY x4	25  3.5 x 34 Bolt (control box) 54058-R25 QTY x2
26  Allen Key 54058-R26 QTY x1	30  Washers 54058-R30 QTY x20	31  Wrench 54058-R31 QTY x1	32  M6 x 45mm Bolts 54058-R32 QTY x2	

PRE-INSTALLED

28  Spring Lock 54058-R28 QTY x8	29  Leg Insert 54058-R29 QTY x4
---	--

ASSEMBLY INSTRUCTIONS

GENERAL NOTE

1. Find a clean, level place to begin the assembly of your QUIKSET® Basketball game. We recommend that two adults work together to assemble this QUIKSET® Basketball game.
2. Remove all the parts from the box and verify that you have all of the listed parts as shown on the parts list page. Carefully cut or tear the four corners of the box so that the bottom of the box can be used as your work surface.

STEP 1

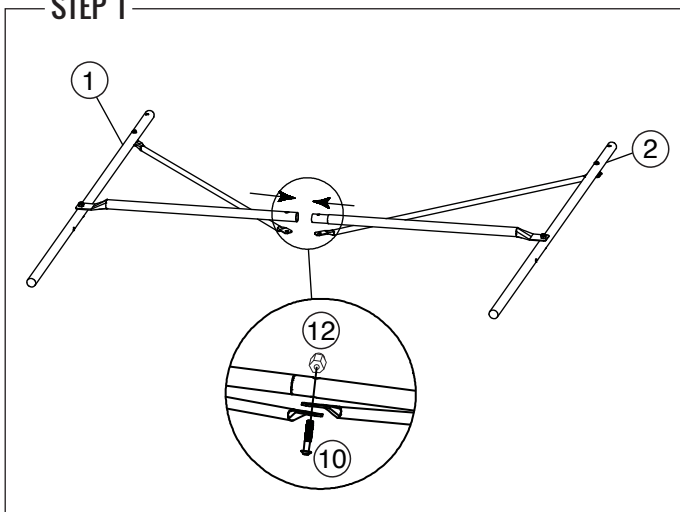

PARTS

1		x1
2		x1
10		x1
12		x1

NOTE

Attach #1 Sub Assembly (Left) (#1) and #1 Sub Assembly (Right) (#2) using 1 Bolt (#10) and 1 Nut (#12).

STEP 2

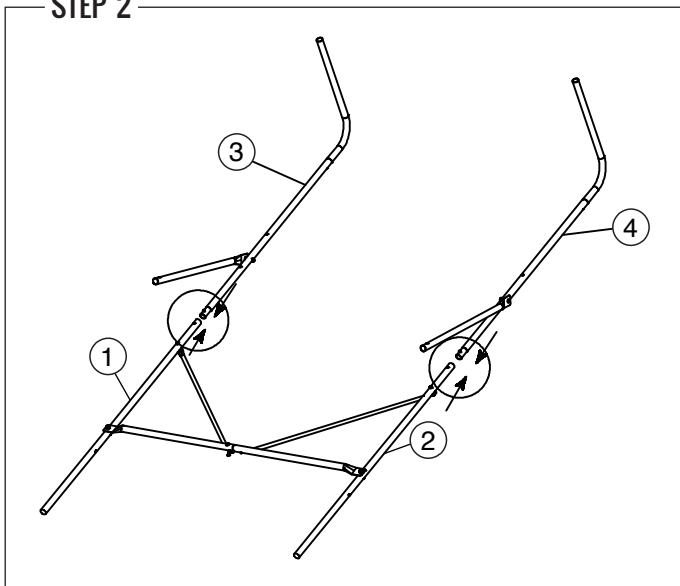

PARTS

3		x1
4		x1

NOTE

Insert #2 Sub Assembly (Left) (#3) and #2 Sub Assembly (Right) (#4) into #1 Sub Assembly (Left) (#1) and #1 Sub Assembly (Right) (#2).

STEP 3

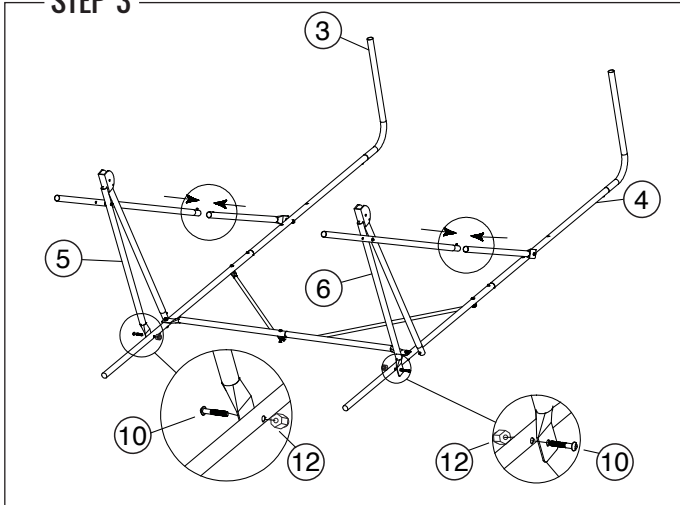

PARTS

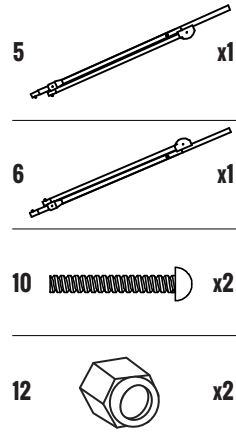

NOTE

Attach **#3 Sub Assembly (Left) (#5)** and **#2 Sub Assembly (Right) (#6)** to sub assembly #1 using **Bolts (#10)** and **Nuts (#12)**.

STEP 4

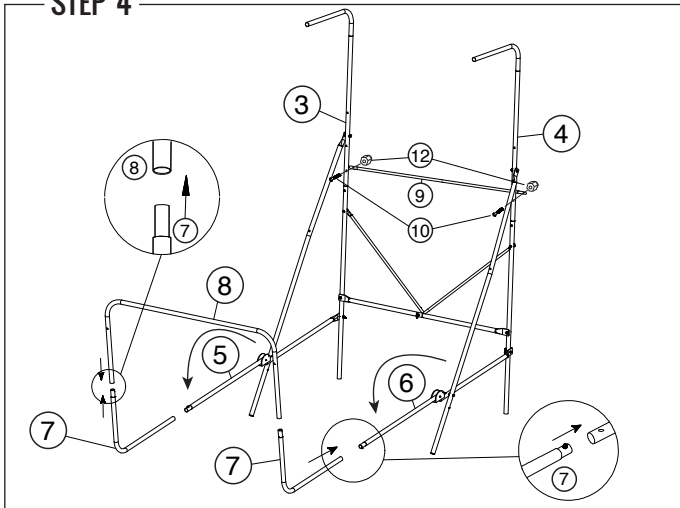

PARTS

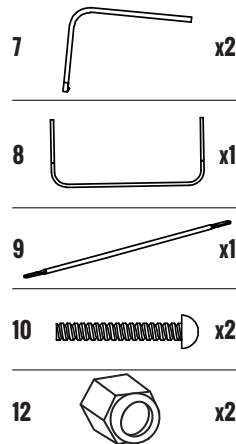

NOTE

Attach the **L-Tubes (#7)** into the **U-Frame (#8)**.

Flip down the two connection tubes off assembly (#5 & #6) and connect to the L-Tubes.

Attach the **Horizontal Bar (#9)** using **Bolts (#10)** and **Nuts (#12)**.

STEP 5

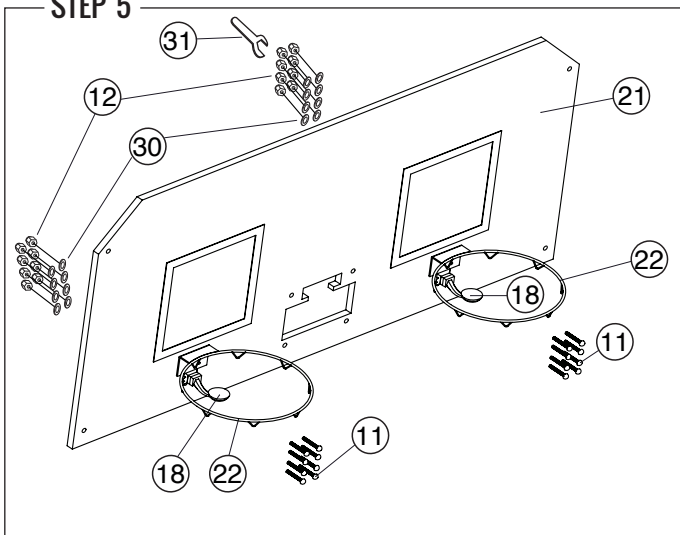

PARTS

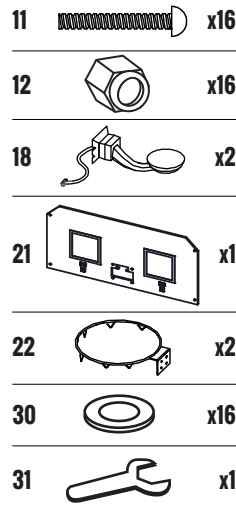

NOTE

Attach the **Rims (#22)** and **Triggering Paddles (#18)** to the **Backboard (#21)** using **Bolts (#11)**, **Nuts (#12)** and **Washers (#30)**.

STEP 6

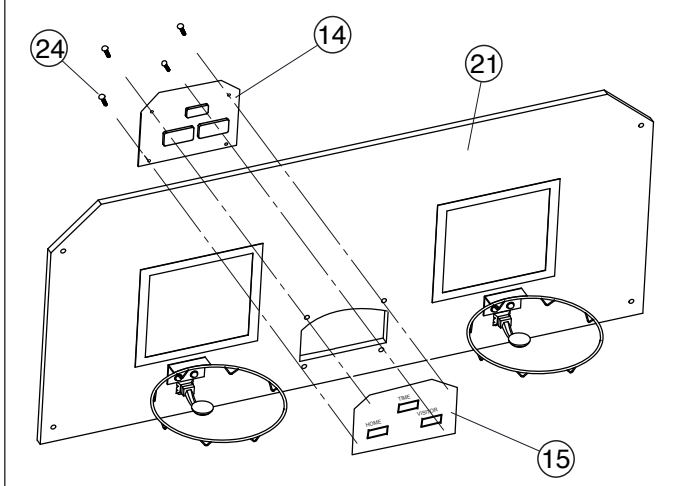

PARTS

14		x1
15		x1
21		x1
24		x4

NOTE

Attach the **Scorer** (#14) and **Scorer Face Plate** (#15) to **Backboard** (#21) using **Wood Screws** (#24).

STEP 7

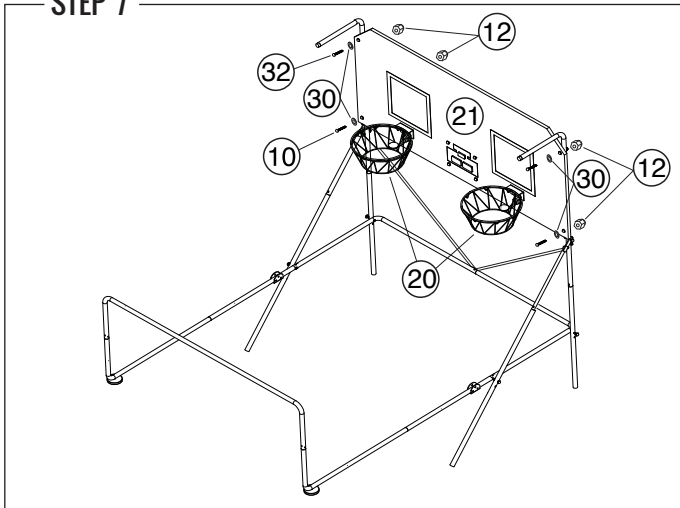

PARTS

10		x4
12		x4
20		x2
21		x1
30		x4
32		x2

NOTE

Attach the **Backboard** (#21) to the frame using **Bolts** (#10 & #32), **Nuts** (#12) and **Washers** (#30).

Do not tighten the bottom nuts until the return net is attached.

Hook **Nets** (#20) to the basketball rims.

STEP 8

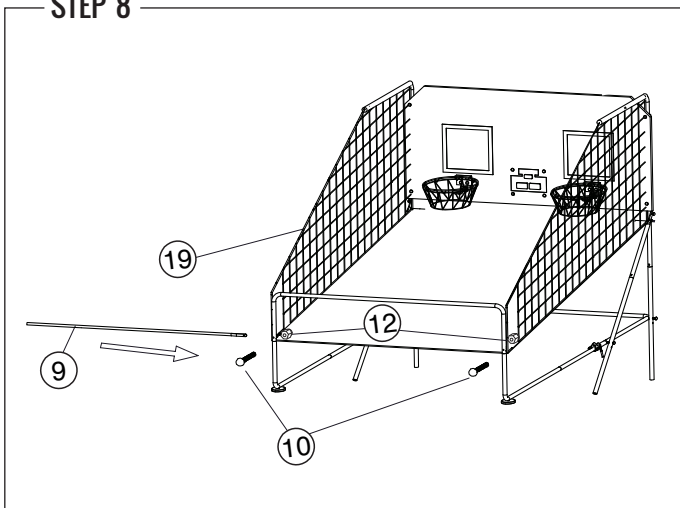

PARTS

9		x1
10		x2
12		x2
19		x1

NOTE

Slip and hook **Ball Return** (#19) onto the frame.

Insert **Horizontal Bar** (#9) into the sleeve of the ball return and attach to the frame using **Bolts** (#10) and **Nuts** (#12).

STEP 9

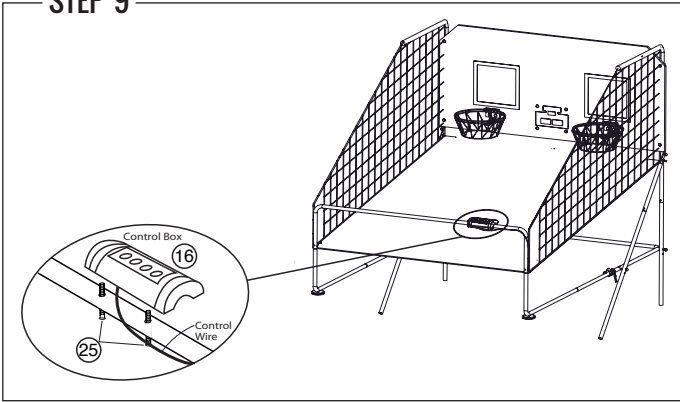

PARTS



NOTE

Attach the **Control Box** (#16) to the u-tube using **Bolts** (#25). Run the **Control Wire** up the side of the ball return.

STEP 10

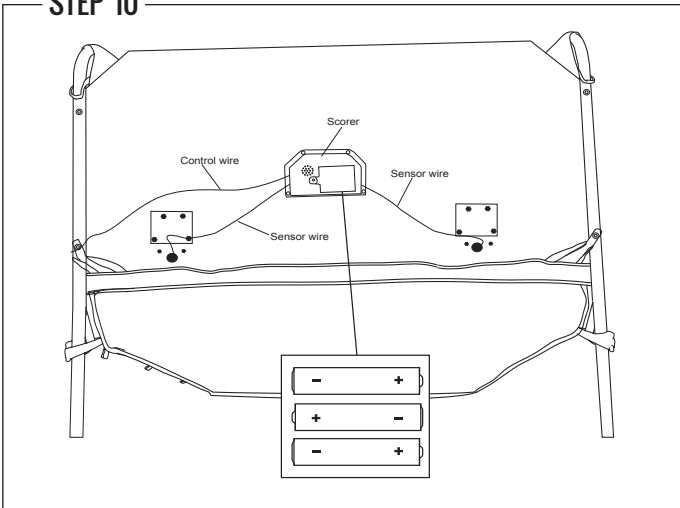

NOTE

Attach the **Control Wire** (#16) and the **Paddle Sensor Wires** (#18) to the **Electronic Scorer** (#14).

NOTE

Requires 3 "AA" size batteries (not included).
Do not mix old and new batteries.
Do not mix alkaline, standard (carbon-zinc), or rechargeable batteries.

YOU ARE NOW READY TO PLAY!

STORAGE

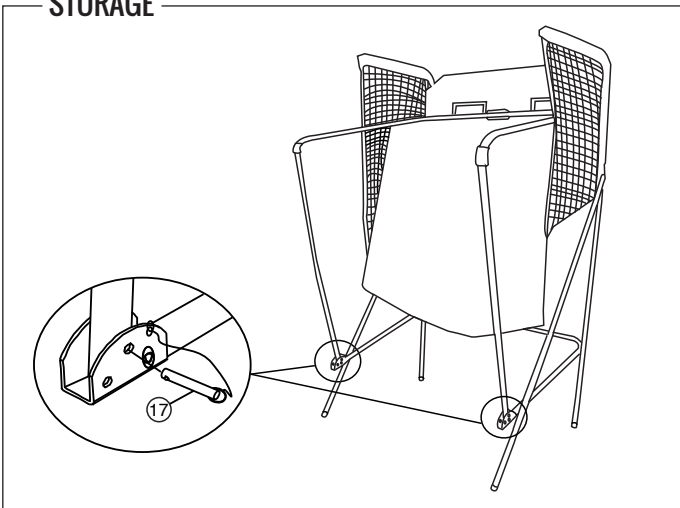

PARTS



NOTE

Fold the ball return upright. Insert **Locking Pins** (#17) through the steel brackets as shown to secure in place.

GAME INSTRUCTIONS

Control Box Operation

- **PRESS "ON/OFF" TO ACTIVATE THE CONTROL BOX (HOLD FOR 5 SECONDS)**

- Scoreboard "HOME" shows "01" (pre- set game 1)
- Press "UP, DOWN" to select a game
- Press "PLAY" to enter selected game mode
- Press "SOUND" to switch sound on/off while playing
- Press "Pause" to pause or start time counting
- Press and hold the button "ON/OFF" 3 seconds to turn off control box
- Press and hold the button "RESET" 3 seconds to reset the game

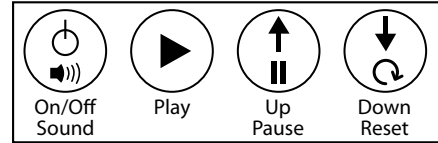

Note: If no shot is made or no button is pressed for 15 mins, control box will be turned off automatically

1. Beat the Time Clock

- Press "PLAY" to enter game 1
- Press "UP/Down" to select single/multiple players (P1/P2/P3/P4)
- Press "PLAY" after the number of player is selected
- Press "UP/Down" to select playing time, 30/45/60 seconds
- Press "PLAY" to begin the game
- Scoreboard "Home" shows Player 1, 3; scoreboard "Visitor" shows Player 2, 4
- All shots worth 2 points until last 10 seconds, each score counts 3 points
- Countdown 5 seconds to next player's turn when one player finishes game
- Player with more points scored wins (LED will flash on player with higher score)
- Press "PLAY" to restart this game

2. 3 Point Beat the Time Clock

- Press "PLAY" to enter game 2
- Press "UP/Down" to select single/multiple players (P1/P2/P3/P4)
- Press "PLAY" after the number of player is selected
- Press "UP/Down" to select playing time, 30/45/60 seconds
- Press "PLAY" to begin the game
- Scoreboard "Home" shows Player 1, 3; scoreboard "Visitor" shows Player 2, 4
- All shots made count 3 points.
- Countdown 5 seconds to next player's turn when one player finishes game
- Player with more points scored wins (LED will flash on player with higher score)
- Press "PLAY" to restart this game

3. Battle Back

- Press "PLAY" to enter game 3
- Press "UP/DOWN" to select players (2P/4P)
- Press "PLAY" to begin the game
- Shot made in "HOME" frame, +2 points scored display on "HOME" board and -2 points for "Visitor"
- Shot made in "Visitor" frame, +2 points scored display on "Visitor" board and -2 points for "HOME"
- Once a player scores 10 points who wins and game is finished
- Press "PLAY" to restart this game

GAME INSTRUCTIONS CONTINUED

4. Horse

- Press "PLAY" to enter game
- Press "UP/Down" to select multiple players (P2/P3/P4)
- Press "PLAY" after the number of player is selected
- Player has to make a shot in 2 seconds.
- First player is allowed to shoot at any hoop (Home or Visitor). If first player scores in 2 seconds, no letter is given. Game continues for next player.
- If player can't score in 2 seconds, player receives the first letter "H" which will display on scoreboard. Game remains for the same player until the player scores.
- The first player to spell "horse" loses. Players stay in repeat step 4.5.6. till game is finished
- The last player to spell "horse" wins
- Press "PLAY" to restart this game

5. Check Point

- Press "PLAY" to enter game 5
- Press "UP/Down" to select single/multiple players (P1/P2/P3/P4)
- Press "PLAY" to begin the game
- "HOME" displays "player", "Visitor" displays "24" points, pre-set 40 seconds playing time
- Points scored will display on scoreboard "HOME"
- Before time is out, once 24/52/68/86 points is scored, playing time increases 10/20/10/20 seconds respectively
- Countdown 5 seconds to next player's turn when one player finishes game
- Player with more points scored wins (LED will flash on player with higher score)
- Game is finished when a player scores 98 points
- Press "PLAY" to restart this game

6. Around the World

- Use tape to mark the shooting lines
- Press "PLAY" to enter game 6
- Press "UP/Down" to select single/multiple players (P1/P2/P3/P4)
- Press "PLAY" after the number of player is selected
- Scoreboard "HOME" displays Player 1/2/3/4, "Visitor" displays scored points
- Once score comes to 10 points or time comes to 99 seconds countdown 5 seconds to next player's turn when one player finishes game
- Player who finishes the game first wins (LED will flash on winner)
- Press "PLAY" to restart this game

7. Left and Right shoot

- Press "PLAY" to enter game 7
- Press "UP/Down" to select single/multiple players (P1/P2/P3/P4)
- Press "PLAY" after the number of player is selected
- Press "UP/Down" to select playing time, 30/45/60 seconds
- Press "PLAY" to begin the game
- Scoreboard "HOME" displays Player, "Visitor" displays points
- Make a shot in "HOME" frame when LED is flashing on "HOME", 2 points will be scored
- Make a shot in "Visitor" frame when LED is flashing on "Visitor", 2 points will be scored
- Countdown 5 seconds to next player's turn when one player finishes game
- Player with more points scored wins (LED will flash on player with higher score)
- Press "PLAY" to restart this game

GAME INSTRUCTIONS CONTINUED

8. One to One

- Press "PLAY" to enter game 8
- Press "UP/Down" to select single/multiple players(1P/2P/3P/4P)
- Press "PLAY" after the number of player is selected.
- Press "UP/Down" to select playing time, 30/45/60 seconds
- Press "PLAY" to begin the game
- Shot made in "HOME" frame, 2 points scored for "HOME", all shots count 3 points in last 10 seconds
- Shot made in "Visitor" frame, 2 points scored for "Visitor", all shots count 3 points in last 10 seconds
- Player with more points scored wins when time is out
- Press "PLAY" to restart this game

CHANGES OR MODIFICATIONS NOT EXPRESSLY APPROVED BY THE PARTY RESPONSIBLE FOR COMPLIANCE COULD VOID THE USER'S AUTHORITY TO OPERATE THE EQUIPMENT.

NOTE: THE EQUIPMENT HAS BEEN TESTED AND FOUND TO COMPLY WITH THE LIMITS FOR A CLASS B DIGITAL DEVICE; PURSUANT TO PART 15 OF THE FCC RULES. THESE LIMITS ARE DESIGNED TO PROVIDE REASONABLE PROTECTION AGAINST HARMFUL INTERFERENCE IN A RESIDENTIAL INSTALLATION. THIS EQUIPMENT GENERATES, USES AND CAN RADIATE RADIO FREQUENCY ENERGY AND, IF NOT INSTALLED AND USED IN ACCORDANCE WITH THE INSTRUCTIONS, MAY CAUSE HARMFUL INTERFERENCE TO RADIO COMMUNICATIONS. HOWEVER, THERE IS NO GUARANTEE THAT INTERFERENCE WILL NOT OCCUR IN A PARTICULAR INSTALLATION. IF THIS EQUIPMENT DOES CAUSE HARMFUL INTERFERENCE TO RADIO OR TELEVISION RECEPTION, WHICH CAN BE DETERMINED BY TURNING THE EQUIPMENT OFF AND ON, THE USER IS ENCOURAGED TO TRY TO CORRECT THE INTERFERENCE BY ONE OR MORE OF THE FOLLOWING MEASURES:

- REORIENT OR RELOCATE THE RECEIVING ANTENNA.
- INCREASE THE SEPARATION BETWEEN THE EQUIPMENT AND RECEIVER.
- CONNECT THE EQUIPMENT INTO AN OUTLET ON A CIRCUIT DIFFERENT FROM THAT TO WHICH THE RECEIVER IS CONNECTED.
- CONSULT THE DEALER OR AN EXPERIENCE RADIO/TV TECHNICIAN FOR HELP.