

TO PLAY WITH TRADITIONAL TEE:

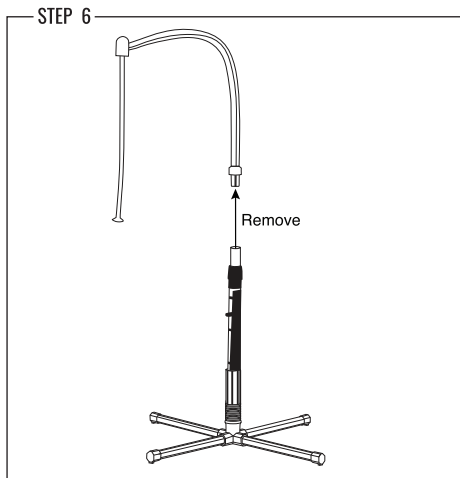

NOTE

Simply remove the **White Arm (E) / Red Hanging Tee (F)** (these will be locked together) from the **Adjustable Tee Tubing (C)**.

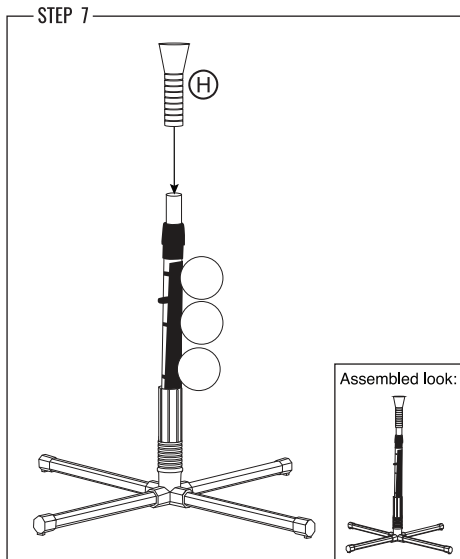

PARTS



NOTE

Take the **Traditional Tee Topper (H)** and assemble to the top of the **Adjustable Tee Tubing (C)**.

YOU ARE NOW READY TO PLAY WITH YOUR TRADITIONAL TEE!

Made In China
Franklin Sports Inc.
Stoughton, MA 02072

Franklin

For replacement parts:
Visit: franklinsports.com/instructions
Email: parts@franklinsports.com
Call: 1-800-225-8649

AGES 3+



2-IN-1 GROW-WITH-ME™ BATTING TEE

ITEM NUMBER: **64119S11**



NOTE: PRINT FRONT TO BACK

Franklin®

CUSTOMER SERVICE COMMITMENT

Thank you for purchasing this Franklin® product! In the event that the product you've purchased has missing or damaged parts, please contact us at:

parts@franklinsports.com

or

Visit our website at: franklinsports.com/instructions

If possible, please include product part number and parts description so we can best assist you.

WE'RE HERE FOR YOU!

PLEASE DO NOT RETURN THIS PRODUCT TO THE STORE IT WAS PURCHASED FROM.

WE ARE COMMITTED TO FULFILLING ALL REPLACEMENT PART NEEDS IMMEDIATELY.

Thank you for your continued support, and welcome to the #FranklinFamily!

Franklin® ITEM#: **64119S11**

1

For replacement parts:
Visit: franklinsports.com/instructions
Email: parts@franklinsports.com
Call: 1-800-225-8649

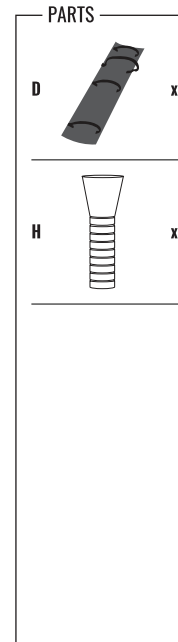
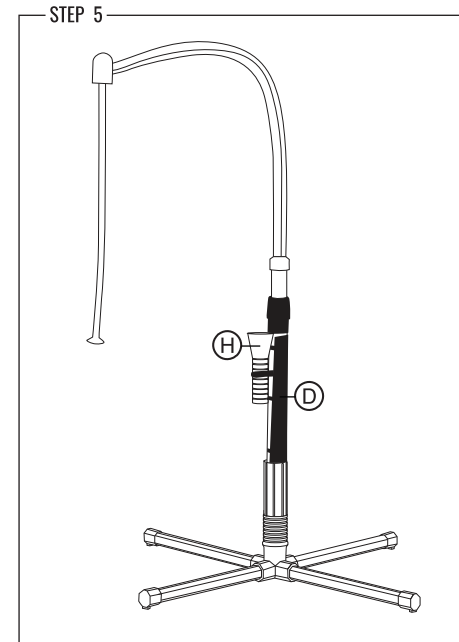

NOTE

Your **Traditional Tee Topper (H)** can fasten to the back of the **Self-Stick Sleeve (D)** when playing with this Hanging Tee version so that you don't have to worry about losing pieces!

YOU ARE NOW READY TO PLAY WITH YOUR HANGING TEE!

Flip for more ways to play!



Franklin® ITEM#: **64119S11**

6

For replacement parts:
Visit: franklinsports.com/instructions
Email: parts@franklinsports.com
Call: 1-800-225-8649

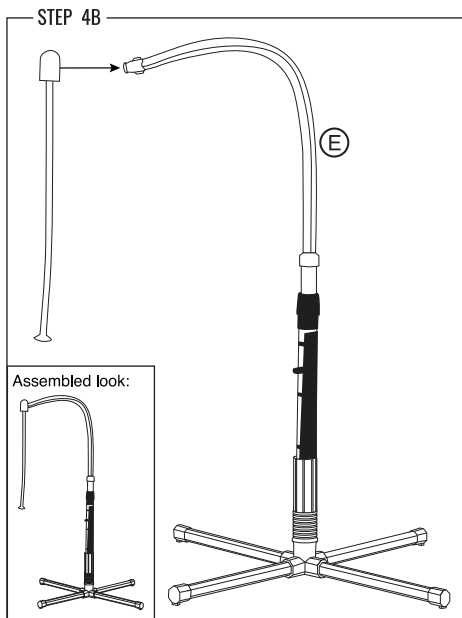
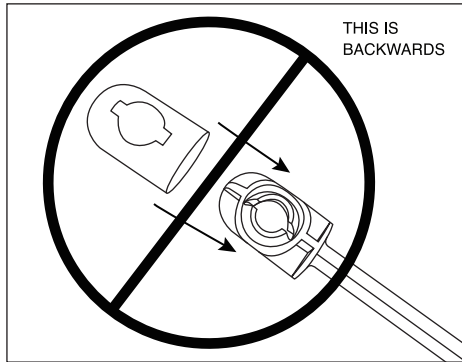
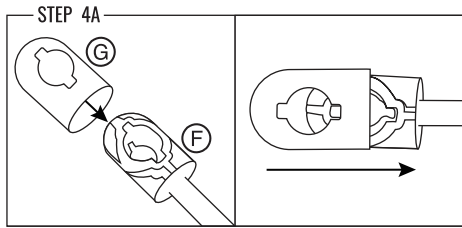

PARTS

E		x1
F		x1
G		x1

NOTE

Turn the **Red Hanging Tee (F)** to its front, and then slide the **Red Cap (G)** over as shown.

Caution: Make sure this piece is assembled correctly. Failure to assemble correctly will result in a red piece that is not properly locked into place on the **White Arm (E)**. If your red piece seems like it isn't locking into place securely, then this step has been assembled incorrectly. Take a look at the images to the left to understand which side is the front and which side is the back.

Once the **Red Cap (G)** has been assembled to the **Red Hanging Tee (F)**, this can be attached and locked to the **White Arm (E)**. The Red Hanging Tee and Red Cap should click & lock into place if assembled correctly. If you find that this Red Hanging Tee comes off of the White Arm easily, then the pieces have been assembled incorrectly.

PARTS LIST

A		QTY x4	B		QTY x1	C		QTY x1
Weighted Legs			Tee Base			Adjustable Tee Tubing		
Rep. Part: 64119-R1			Rep. Part: 64119-R2			Rep. Part: 64119-R3		
D		QTY x1	E		QTY x1	F		QTY x1
Self-Stick Sleeve			White Arm			Red Hanging Tee		
Rep. Part: 64119-R4			Rep. Part: 64119-R5			Rep. Part: 64119-R6		
G		QTY x1	H		QTY x1	I		QTY x4
Red Cap			Traditional Tee Topper			Baseballs		
Rep. Part: 64119-R7			Rep. Part: 64119-R8			Rep. Part: 64119-R9		
J		QTY x1						
Bat			Rep. Part: N/A					

ASSEMBLY INSTRUCTIONS

GENERAL NOTE

- Remove all components from packaging.
- Sort all components using the parts list and confirm that all parts are included.

STEP 1

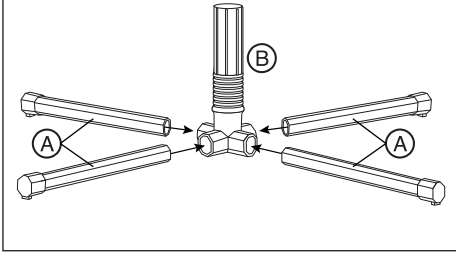

PARTS

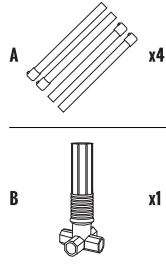

NOTE

Insert **Weighted Legs (A)** into **Tee Base (B)** as shown.

STEP 2

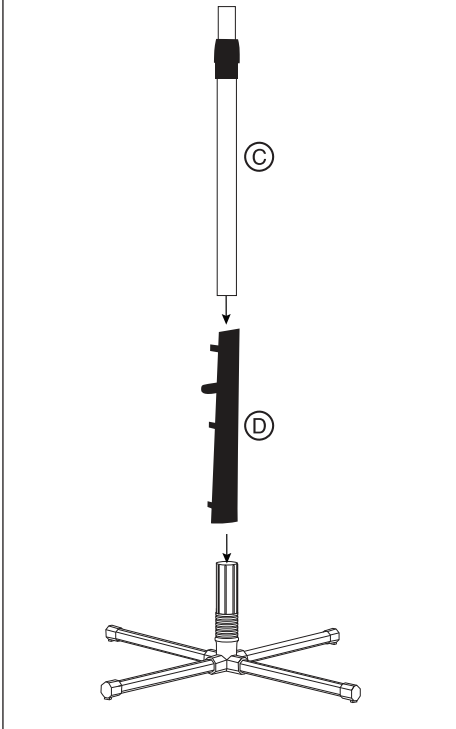

PARTS

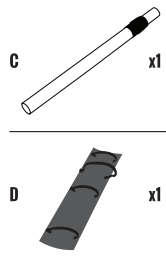

NOTE

Slide the **Adjustable Tee Tubing (C)** through the **Self-Stick Sleeve (D)**. Once this is done, attach the **Adjustable Tee Tubing (C)** to the base as shown.

STEP 3

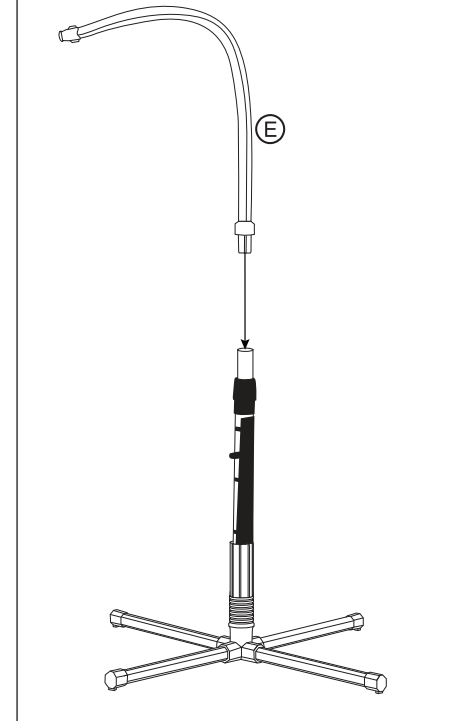

PARTS

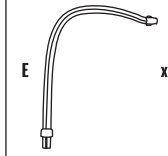

NOTE

Attach the **White Arm (E)** to the tee as shown.