

STEP 2

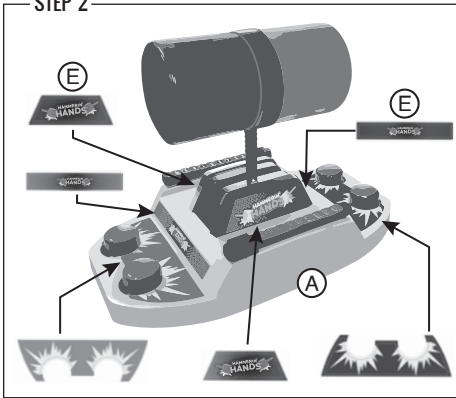

PARTS

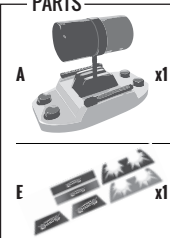

NOTE

Apply the stickers from the **Sticker Sheet (E)** onto the **Hammerin' Hands Base Unit (A)** as shown.

STEP 3

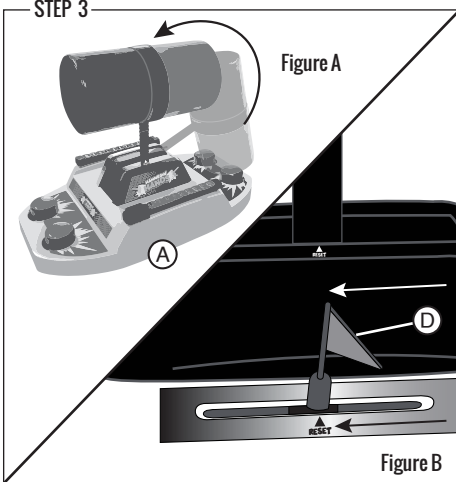

PARTS

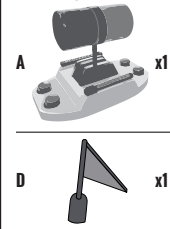

NOTE

**DURING GAME PLAY:** Before each round begins, the hammer must be reset. Pull the hammer back up to the center so it's standing upright (Fig. A). Then, adjust the Game Lever Flag on the side of the hammer so it perfectly aligns with the "RESET" arrow (Fig. B). This will ensure that the hammer is in the center of each team for a fair game each time!

**YOU ARE NOW READY TO PLAY!**

**Head over to the HAMMERIN' HANDS Game Sheet to see full rules on how to play!**

Made In China  
Franklin Sports Inc.  
Stoughton, MA 02072



For replacement parts:  
Visit: [franklinsports.com/instructions](http://franklinsports.com/instructions)  
Email: [parts@franklinsports.com](mailto:parts@franklinsports.com)  
Call: 1-800-225-8649

Ages 3+

**FRANKLIN**®



ITEM NUMBER: **69002**



**NOTE: PRINT FRONT TO BACK**



## CUSTOMER SERVICE COMMITMENT

Thank you for purchasing this Franklin® product! In the event that the product you've purchased has missing or damaged parts, please contact us at:

[parts@franklinsports.com](mailto:parts@franklinsports.com)

or

Visit our website at: [franklinsports.com/instructions](http://franklinsports.com/instructions)

If possible, please include product part number and parts description so we can best assist you.





# WE'RE HERE FOR YOU!

**PLEASE DO NOT RETURN THIS PRODUCT TO THE STORE IT WAS PURCHASED FROM.**

**WE ARE COMMITTED TO FULFILLING ALL REPLACEMENT PART NEEDS IMMEDIATELY.**

Thank you for your continued support, and welcome to the #FranklinFamily!

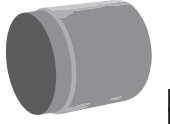
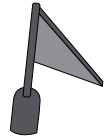
## PARTS LIST

 <p><b>A</b></p> <p>QTY x1</p>	 <p><b>B</b></p> <p>QTY x1</p>	 <p><b>C</b></p> <p>QTY x1</p>
<p>Hammerin' Hands Base Unit</p>	<p>Blue Hammer</p>	<p>Red Hammer</p>
 <p><b>D</b></p> <p>QTY x1</p>	 <p><b>E</b></p> <p>QTY x1</p>	
<p>Victory Flag</p>	<p>Sticker Sheet</p>	

## ASSEMBLY INSTRUCTIONS

### GENERAL NOTES

Remove the product from the box and make sure all parts from the parts list are included. Find a clean, level place to begin the assembly of your HAMMERIN' HANDS® game.

### STEP 1

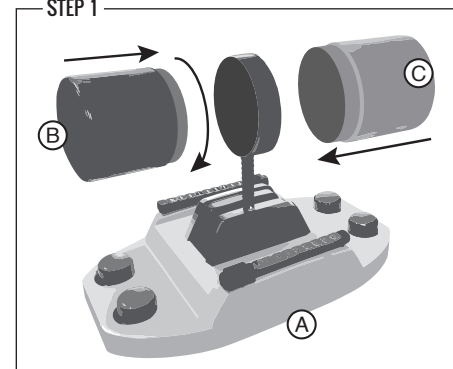

### PARTS

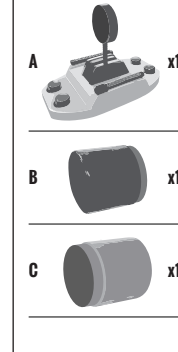

### NOTE

Twist and lock the **Blue Hammer (B)** into the **Hammerin' Hands Base Unit (A)** as shown.

Repeat this process for **Red Hammer (C)** on the other side of the **Hammerin' Hands Base Unit (A)** as shown.