

franklin[®]

30IN (76.2CM)
PORTABLE BASKETBALL

ITEM NUMBER: **91017X** **91017C1X**

www.franklinsports.com/91017X



⚠ WARNING:
CHOKING HAZARD--Small parts.
Not for children under 3 yrs.
Adult assembly required.

Franklin®

CUSTOMER SERVICE COMMITMENT

Thank you for purchasing this Franklin® product! In the event that the product you've purchased has missing or damaged parts, please contact us at:

parts@franklinsports.com

or

Visit our website at: **www.franklinsports.com**

If possible, please include product part number and parts description so we can best assist you.

WE'RE HERE FOR YOU!

PLEASE DO NOT RETURN THIS PRODUCT TO THE STORE IT WAS PURCHASED FROM.

WE ARE COMMITTED TO FULFILLING ALL REPLACEMENT PART NEEDS IMMEDIATELY.

Thank you for your continued support, and welcome to the #FranklinFamily!



SAFETY INSTRUCTIONS



FAILURE TO FOLLOW THESE SAFETY INSTRUCTIONS MAY RESULT IN SERIOUS INJURY AND/OR PROPERTY DAMAGE AND WILL VOID WARRANTY.











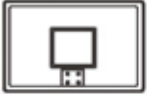

















Owner must ensure that all players know and follow these rules for safe operation of the system.

To ensure safety, do not attempt to assemble this system without following the instructions carefully. Check entire box and inside all packing material for parts and/or additional instruction material. Before beginning assembly, read the instructions and identify parts using the hardware identifier and parts list in this document. Proper and complete assembly, use, and supervision are essential for proper operation and to reduce the risk of accident or injury. A high probability of serious injury exists if this system is not installed, maintained and operated properly.

- 2 capable adults are recommended for this operation.
- Check base daily for leakage. Leaks will cause system to fall.
- Assemble the pole sections properly. Failure to do so could cause the pole sections to separate during play or transport.

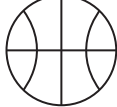
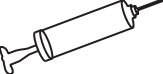
Most injuries are caused by misuse and/or not following instructions. Use caution when using this system.

PARTS LIST

A  Backboard QTY x1	B  Rim QTY x1	B1  Rim QTY x1	B2  Rim QTY x1	C  Base QTY x1	D  Bottom Pole QTY x1		
E  Middle Pole with Warning Label QTY x1	F  Top Pole QTY x1	G  Support Arm QTY x1 Rep. Part: 92004X-R1	H  Axle QTY x2 Rep. Part: 92004X-R2	I  Y Bracket QTY x2			
J  Wheel QTY x2	K  Plastic Nut QTY x1	L PRE-INSTALLED  Top Pole Cap QTY x1	M  Base Cap QTY x1	N  Triangle Nut QTY x1			
O  Lock Nut M8 QTY x10	P  Washer M8 QTY x18	1  Bolt M8 x 20mm QTY x2	2  Bolt M8 x 35mm QTY x4	3  Bolt M8 x 55mm QTY x3	4  Bolt M8 x 60mm QTY x1	5  Bolt M8 x 65mm QTY x1	
6  Bolt M6 x 8mm QTY x2	7  Washer M6 QTY x2	8  Ball QTY x1	9  Pump & Needle QTY x1	Tools Required (NOT INCLUDED)  Adjustable Wrench		 13mm Wrench	 14mm Wrench

ASSEMBLY INSTRUCTIONS

GENERAL NOTE

1. Remove all components from the shipping carton. Remove all protective wrap and layout all components on the ground.
2. Ensure you have all components shown in the parts list.

STEP 1

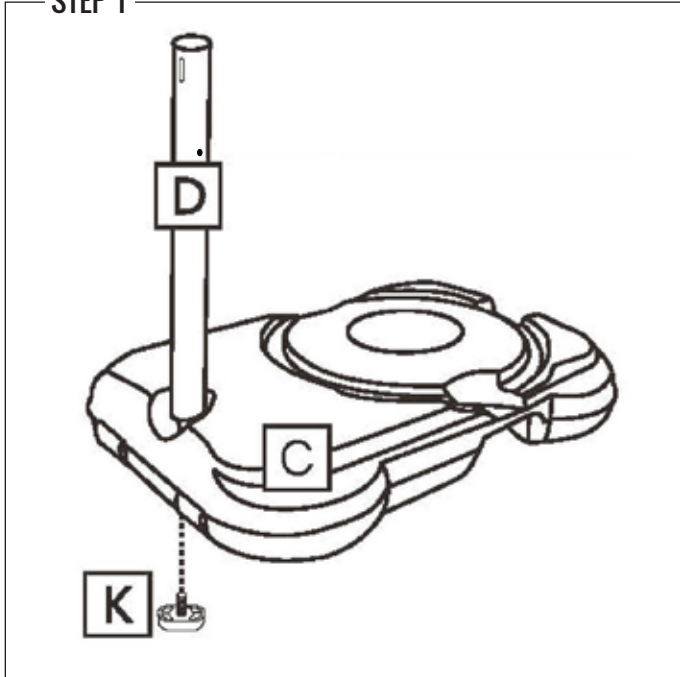

PARTS



NOTE

Attach the **Bottom Pole (D)** on the groove on the **Base (C)**; then secure it by using the **Plastic Nut (K)**.

NOTE:
Make sure that the two holes on the pole are positioned on the sides.

STEP 2

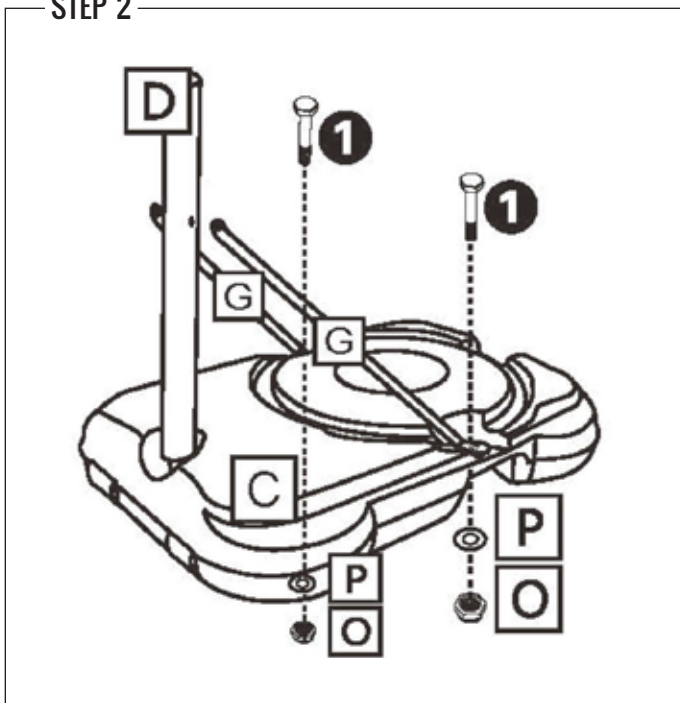

PARTS



NOTE

Attach the **Support Arms (G)** on the **Base (C)** by using 2pcs of **Bolts M8x20mm (1)** through 2pcs of **Washers (P)** and 2pcs of **Nuts (O)**.

NOTE:
Do not fully tighten bolts during this step. It will allow for easier assembly if they are tightened later.

STEP 3 & 4

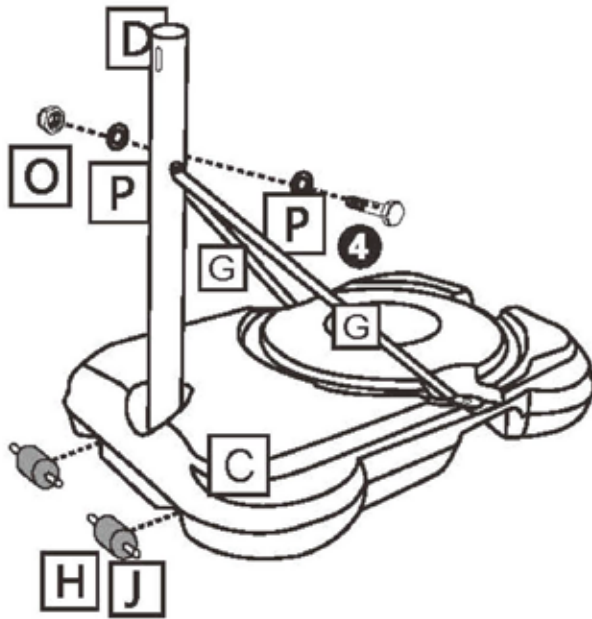

PARTS

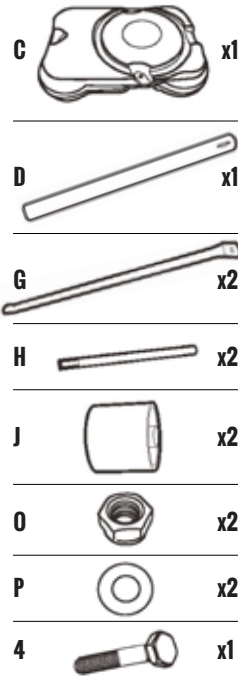

NOTE

Attach the **Support Arms (G)** to **Bottom Pole (D)** by using 1pc of **Bolt M8x60mm (4)** through 2pcs of **Washers (P)** and 1pc of **Nut (O)**.

Insert the **Axles (H)** into **Wheels (J)** and push them into the grooves of the **Base (C)**.

STEP 5

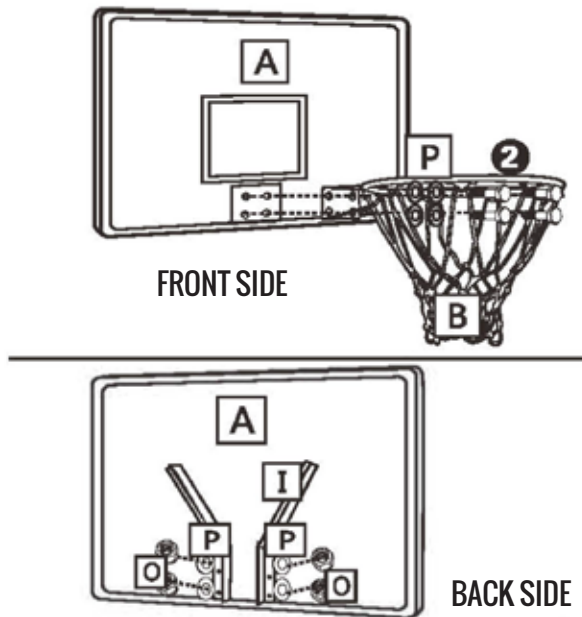

PARTS

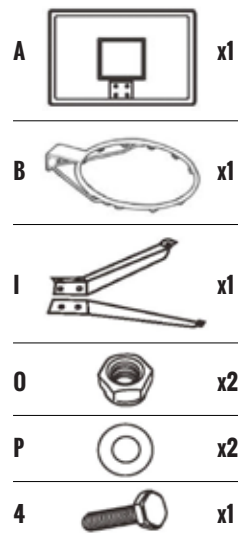

NOTE

Attach the **Rim (B1)** to the front side of **Backboard (A)** using 4pcs of **Bolts M8x35mm (2)** through the **Rim (B1)**, **Backboard (A)**, **Y-Bracket (I)**, 8pcs of **Washers (P)**, and then lock them with 4pcs of **Nuts (O)**.

STEP 6

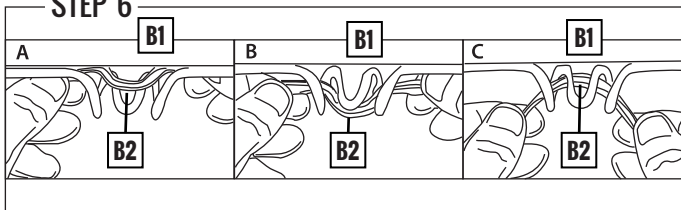

PARTS

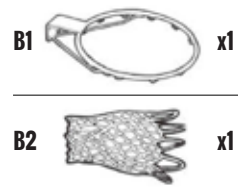

NOTE

Attach **Net (B2)** to **Rim (#B1)** as shown.

STEP 7

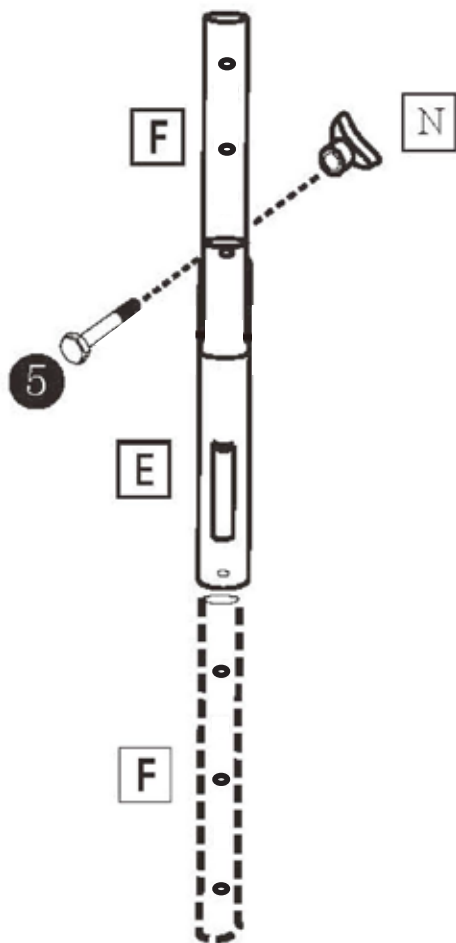

PARTS



NOTE

Slide the **Top Pole (F)** through the **Middle Pole (E)** until it comes out from the top of the middle pole. Make sure there are two holes on each side of the top pole protruding from the middle pole for backboard assembly.

Insert the **Top Pole (F)** up inside the Middle Pole (E). Insert the square **Bolt M8x65mm (5)** and lock it with the **Triangle Nut (N)**.

NOTE:

1. Pole (F) comes packaged inside pole (E). Do not separate. Only need to slide pole (F) up through pole (E).
2. The square bolt M8x65mm (5) has a position fix point at the top of bolt. It helps secure the pole. Make sure this is well inserted into the pole.
3. Check the warning label on the middle pole (E), and make sure it faces user/front and the triangle nut (N) is at the back.
4. The remaining holes in the Top Pole (F) are for height adjusting, including : 5.5ft (1.69m), 5.9ft (1.79m) and 6.4ft (1.95m).

STEP 8

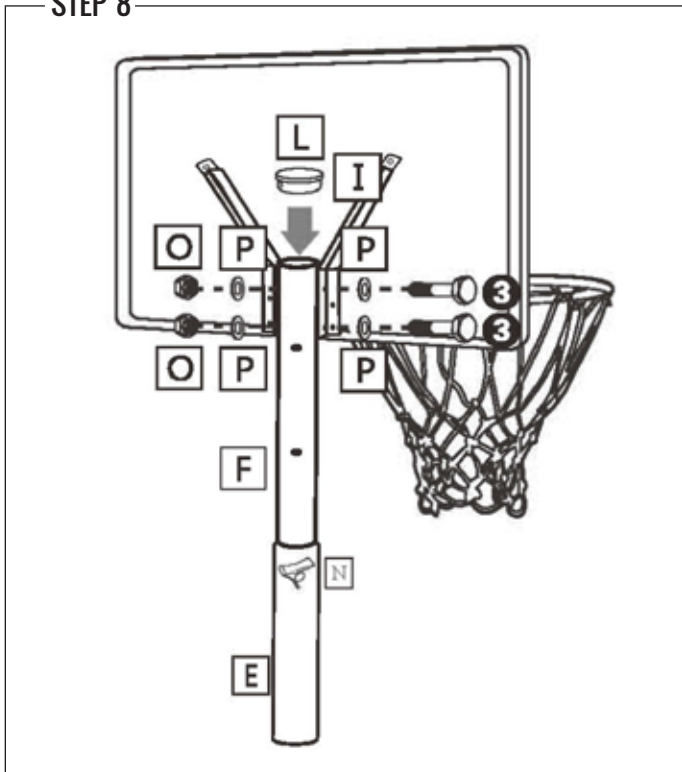

PARTS

E		x1
F		x1
I		x1
L		x1
O		x2
P		x2
3		x2

NOTE

Attach the **Top Pole** (F) inside the **Y-Bracket** (I) at the joint using 2pcs of **Bolts M8x55mm** (3) and 4pcs of **Washers** (P). Lock it with 2 pcs of **Nuts** (O) and insert the **Cap** (L) into the **Top Pole** (F).

STEP 9

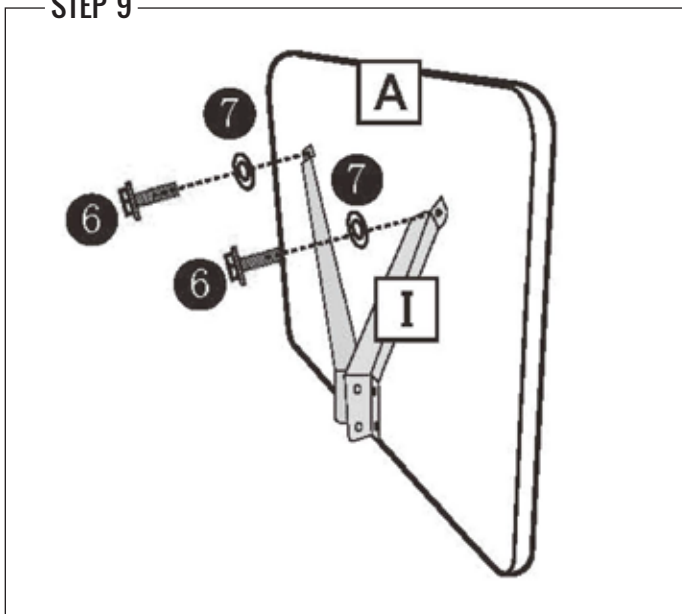

PARTS

A		x1
I		x1
6		x2
7		x2



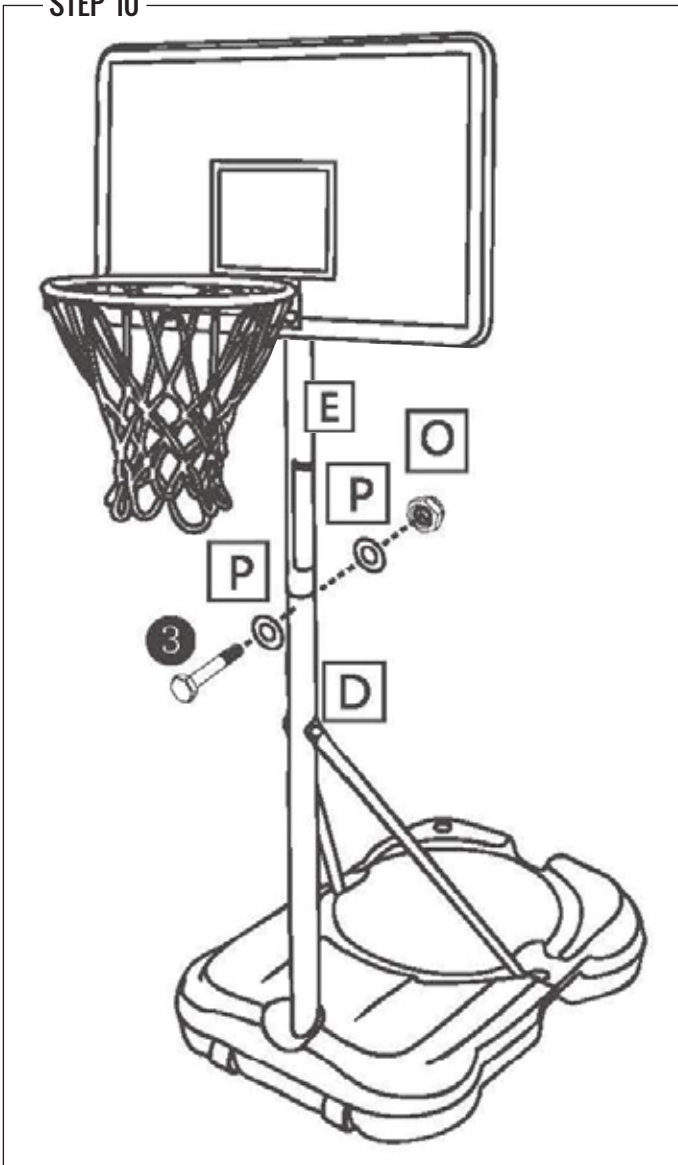

NOTE

Attach the **Y-Bracket** (I) on the backside of **Backboard** (A) by using 2pcs of **Washers M6** (7) and 2pcs of **Bolts M6X8mm** (6).

STEP 10



PARTS

D		x1
E		x1
O		x1
P		x2
3		x1

NOTE

Insert the **Middle Pole** (E) inside the **Bottom Pole** (D) and secure by using **Bolt M8x55mm** (3), 2pcs of **Washers** (P), and 1pc of **Nut** (O).

NOTE:
Make sure all hardware is fully tightened before moving or playing.

STFP 11

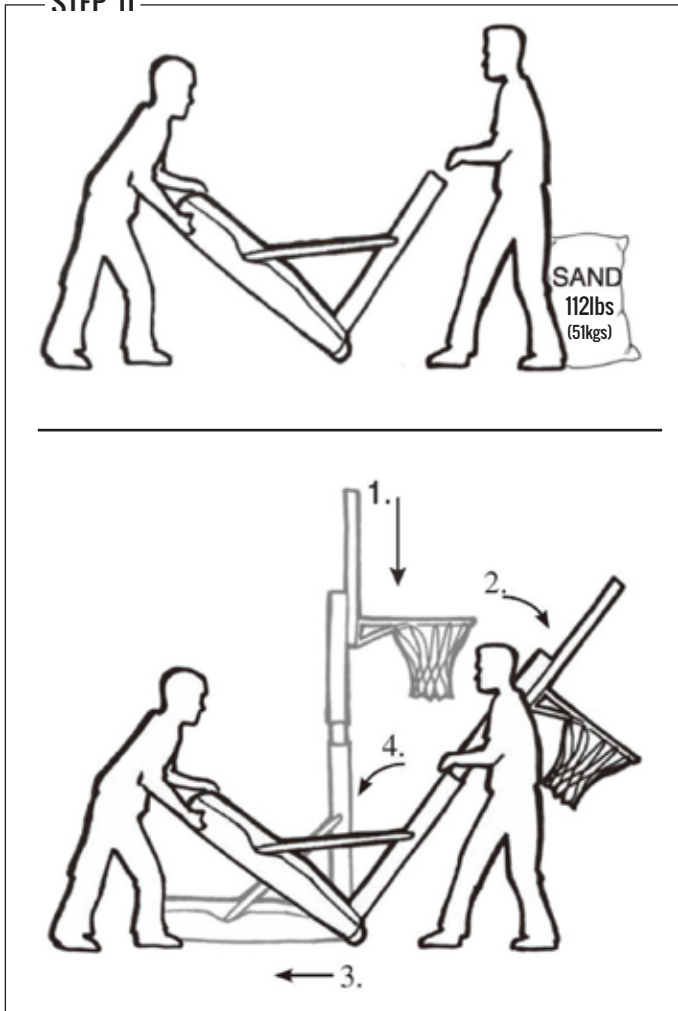

NOTE

Adjust backboard to lowest position.

While holding pole and lifting base, carefully lean system forward until wheels touch ground.

While holding pole and base, roll system to desired location.

Stand pole upright and set base flat on ground.

ALWAYS check to make sure system is stable in new location.

Place base where it will be used. Unscrew and remove base cap.

Pour sand while base is flat on the ground, and then tip forward to allow even distribution.

Repeat the action until the base is full of sand.

Once full, replace base cap.



WARNING:

For safety reasons, we recommend that sand be used instead of water to fill the base. If a leak develops, water could run out unnoticed, allowing the system to fall over, resulting in serious injuries, or property damage. If using water, check the base carefully for leaks. If a leak is found, lay the system down on the ground and call customer service. Do not use, stand up, or play on a leaking system.

MOVING THE SYSTEM



WARNING:

The system must only be moved by at least 2 adults that are capable of handling weight. DO NOT allow children to move unit.

- Adjust the system to its lowest position and lock in place to prevent the height mechanism from adjusting.
- Standing in front of the unit, pull the pole down until it is balanced on the 2 wheels.
- Move the unit to the desired location and carefully lower the unit back down.



CAUTION:

The system must only be moved when balanced on the wheels. Sliding the unit any other way may cause damage to the base and could result in sand leakage and/or system tipping over.



WARNING



FAILURE TO FOLLOW THESE WARNINGS MAY RESULT IN SERIOUS INJURY AND/OR PROPERTY DAMAGE.

Owner must ensure that all players know and follow these rules for operation of the system.

- Only hang from the rim briefly to regain balance or avoid injuring others. Release the rim as safely as possible.
- During play, especially when performing dunk type activities, keep players face away from the backboard, rim and net. Serious injuries could occur if teeth/face come in contact with backboard, rim, or net.
- Do not slide, climb, or play on base or pole.
- Completely fill base according to manufacturers instructions or the system will tip quickly causing serious personal injury.
- When adjusting height or moving system, keep hands and fingers away from moving parts.
- Do not allow children to move or adjust system.
- During play, do not wear jewelry (rings, watches, necklaces, etc.) Objects may entangle in net.
- Surface beneath the base must be smooth and free of gravel or other objects. Punctures can cause leakage and could cause system to tip over.
- Keep water and organic materials away from pole. Pole can rust and fall.
- Once a month check pole and all metal parts for rust. Completely remove rust and repaint with exterior enamel. If rust has penetrated any steel part, replace that part immediately.
- Check system before each use for proper ballast, loose hardware, instability, and signs of corrosion and repair before each use. Never play on damaged equipment.
- Do not use system during windy or severe weather. System may tip over. Place system in an area protected from the wind or in an area away from property that may be damaged if the system falls.

FRANKLIN SPORTS

1-800-225-8649



WARNING:

Failure to observe this warning may cause property damage and/or serious injury.

This product is NOT designed to support a player hanging from any component of this basketball system.

Rim height adjustments should be made by ADULTS ONLY.

Wear a mouth guard when playing to avoid dental injuries.

During play, do not wear jewelry (rings, watches, necklaces, etc.).

Objects may entangle in net.



WARNING:

**SWINGING ON THIS RIM
MAY CAUSE SERIOUS INJURY
OR DEATH.**



WARNING:

**DO NOT LEAVE UNIT IN VERTICAL
POSITION IF THE BASE IS NOT
PROPERLY FILLED WITH SAND.**

YOU ARE NOW READY TO PLAY!

Franklin®

Made In China
Franklin Sports Inc.
Stoughton, MA 02072